

# SIGNS

## OPPORTUNITIES FOR REAL ESTATE, PROPERTY MANAGEMENT, CONSTRUCTION AND SHOW HOME SIGNS

### TEMPORARY AND PERMANENT SIGNS

There are many opportunities for real estate and property management signs on both public and private property.

#### SIGNS ON PUBLIC PROPERTY

On public property, within the side boulevards of the roads, a temporary sign up to 0.6 m<sup>2</sup> in area can be placed for up to 14 days. These signs can present real estate or property management information. There are placement criteria and some roadway limitations. Please refer to Bylaw 29M97 for all pertinent regulations.

No permanent signs are allowed on public property for these purposes.

#### SIGNS ON PRIVATE PROPERTY

There are permanent and temporary sign opportunities available. Please refer to the Sign Appendix of the Land Use Bylaw 2P80 for full regulations.

The definitions of real estate and property management signs are:

“**property management sign** means a sign that identifies the party responsible for the management of the site and any necessary sales, leasing or rental information;”

“**real estate copy** means copy that advertises real estate that is “for sale”, “for lease”, or “for rent or real estate that has been sold;”

“**real estate sign** means a sign displaying real estate copy;”

“**construction sign** means a sign erected by an individual or a firm on the premises undergoing construction, for which the sign user is advertising or furnishing such items as labour, services, materials or financing, or which identifies the future use on the site and information pertaining to it;”

“**show home** means a newly constructed residential dwelling which is utilized for a short period of time as an exhibit of the type of dwelling a builder is providing in a community;”

#### SIGN OPPORTUNITIES

Where there is a permanent sign on the site frontage, real estate and property management information must be displayed on the permanent sign. Innovative presentation indicating vacancies include “flip-down” features and use of vacant sign panels.

#### Permanent Sign Opportunities

##### On a building face:

The sign must be a fascia sign and must be located in an approved sign band area. Only one fascia sign per building face is allowed. The sign area cannot exceed 1.5 m<sup>2</sup> in area on a building frontage less than or equal to 30 metres in length. On a building frontage exceeding 30 metres in length, the maximum sign area allowed is 3.0 m<sup>2</sup>.

##### On a freestanding sign:

If there is a freestanding identification sign on the site, the real estate or property management sign must be included on this sign. The maximum area



for the sign is 80 per cent of the sign area, or 3.0 m<sup>2</sup>, whichever is less.

Where a permanent sign does not exist, and there is an ongoing, regular need for presenting real estate or property management information, it is recommended that a permanent sign be installed.



If there is a message sign on the site it can also be used to display real estate and property management information.

#### Temporary Sign Opportunities

A temporary sign is not permanently anchored to the ground, to a structure or permanently affixed to a permanent sign. No permit is required to display temporary real estate, show home, property management or construction signs which meet all the rules of the Land Use Bylaw.



However, a temporary freestanding sign, greater than 1.5 m<sup>2</sup> must be located on an approved temporary sign location which requires a discretionary development permit.

### Temporary Freestanding Signs on Residential Sites

If there is no freestanding identification sign on the site, one freestanding property management sign or real estate sign may be allowed per site frontage.

On low density residential sites (RR-1, R-1, RS-2, R-1A, R-2, and R-2A) the maximum sign allowed is 1.0 m<sup>2</sup> and 2 metres high.

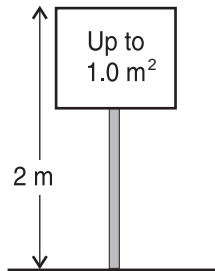

On multi-dwelling residential sites with a frontage equal to or less than 30 metres, the maximum sign is 1.5 m<sup>2</sup> in area and the maximum height is 2 m.

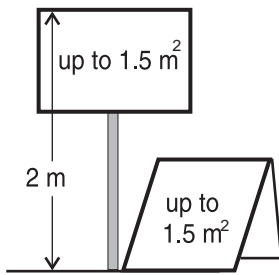

On multi-dwelling residential sites with a frontage greater than 30 metres, the maximum sign allowed is 3.0 m<sup>2</sup> and 3 metres high. Any sign larger than 1.5 m<sup>2</sup> must be located on an approved temporary sign location.

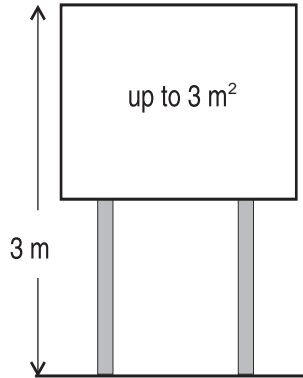

Signs on a show home site are allowed to a maximum sign area of 3.0 m<sup>2</sup> and the area of all the signs on the site cannot exceed 6.0 m<sup>2</sup>.

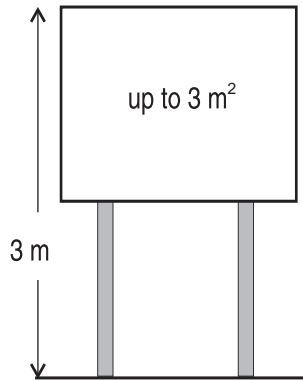

### Temporary Banner Sign on Residential Sites

On multi-dwelling residential buildings that exceed 3 storeys, a banner sign may be placed on the building for a period not to exceed 90 days following the issuance of a Development Completion Permit.

### Temporary Freestanding Signs on Non-Residential Sites

Property management and real estate information must be located on the freestanding identification sign on the site. However, if there is no freestanding

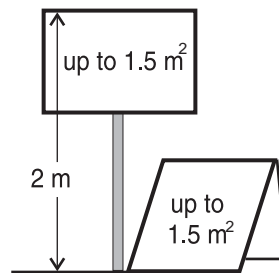

identification sign on the site, one freestanding property management sign or real estate sign may be allowed. On sites equal to or less than 30 metres in length, the maximum sign area allowed is 1.5 m<sup>2</sup> and the maximum height is 2 m.

On sites with a frontage exceeding 30 metres in length, the maximum sign area allowed is 3.0 m<sup>2</sup> and the maximum height is 3.0 m.

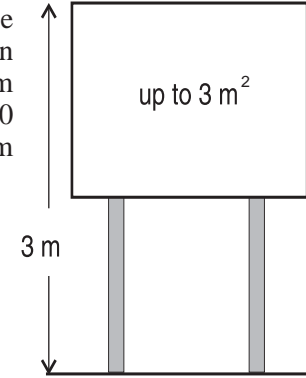

### Temporary Banner Signs on Non-Residential Sites

A banner may be placed in the fascia sign area or in the panel area of a freestanding identification sign as a real estate sign while the related space is unoccupied.



### Temporary Freestanding Signs on Undeveloped Sites (Residential and Non-Residential)

On undeveloped sites the maximum sign area for a construction or real estate sign is

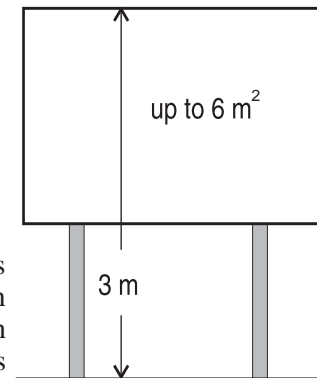

6.0 m<sup>2</sup> and the sign must be removed within 7 days of the issuance of a Development Completion Permit for the development on the site. Prior to using signs on Public Property, please refer to *City of Calgary Bylaw 29M97* (available from the City Clerk's Department).

Prior to using signs on private property, please refer to the *Sign Appendix of Land Use Bylaw 2P80* (available from Planning and Transportation Policy Information Centre).

### FURTHER INFORMATION

The City of Calgary  
 Development & Building Approvals  
 Customer Service Counter  
 3rd Floor, Calgary Municipal Building  
 800 Macleod Trail SE, Calgary, AB  
 Phone: (403) 268-5311  
 Website: [www.calgary.ca/planning](http://www.calgary.ca/planning)

*This series is published by The City of Calgary, Development & Building Approvals, as part of a public information service.*

*These pamphlets have no legal status and cannot be used as an official interpretation of the various codes and regulations currently in effect. The City of Calgary accepts no responsibility to persons relying solely on this information.*

*Pamphlets are updated periodically. Contact Development & Building Approvals at 268-5311 to determine if you have the most recent edition.*