

2013 & 2014 Business Plans and Budget Adjustments

JUNE ENGAGEMENT RESULTS

 OUR CITY
 OUR BUDGET
 OUR FUTURE



calgary.ca | call 3-1-1

Onward/ By 2016, Calgary City Council establishes a participatory budgeting process.



THE CITY OF
CALGARY

Table of Contents

1) Executive Summary	2
2) Survey Results	5
Appendix A	17
Appendix B	24
Appendix C	29
3) Comments from calgary.ca/ourfuture comment boxes	32
4) Web metric report for calgary.ca/ourfuture	34

2013 & 2014 Business Plans and Budget Adjustments Engagement Phase 1 - June 2012

Executive Summary

On 2011 November 29, Council approved the 2012-2014 business plans and budgets. This was accomplished thanks to over 23,000 Calgarians who took the opportunity to learn more about The City's plans, how we use our revenues and thoughtfully shared with us their ideas on what priorities we should consider from 2012 to 2014.

To honour The City's commitment to Calgarians, we created a micro site, calgary.ca/ourfuture, to enable The City to continue its conversation with Calgarians. The site was launched on June 12, 2012, and contained information and links designed to give Calgarians information regarding the approved 2012 – 2014 business plans and budgets so they could become more informed on what The City is focusing its efforts towards, how we are spending tax and capital dollars and to give them a forum to talk directly with The City and each other.

The priority for citizen engagement at this time was to discover if Calgarians' priorities had changed since Council deliberation in 2011, if outside events had changed or shifted (e.g.. economic conditions) from their perspective, and if The City was doing a good job in meeting the expectations laid out in the 2012 – 2014 business plans and budgets.

Information presented in this report was gathered from an online survey that ran from 2012 June 12 – 30, along with comment boxes that are available on every page of the micro site. Web metrics for the time the site has been active are also supplied in this report, along with the link to the citizen engagement completed as part of the 2012 – 2014 business planning and budgeting program.

Citizens and City employees were made aware of this micro site, and the opportunity to continue our conversation through multiple means. The City used the citynews blog, facebook, twitter, Google ads, calgary.ca ads and digital displays to reach Calgarians as well as internal use of myCity and partnership with community groups to share the site with their audiences. Digital mediums were used to continue the conversation following the recommendations made through the 2012 – 2014 Business Planning and Budgeting report.

Our commitment to citizens through the entire 2013 & 2014 Adjustments period is to:

- Reflect a strong focus on transforming government, including transparency, accountability and engagement as reflected in Council's Fiscal Plan for Calgary.
- Ensure that the transformational approach to engaging citizens that began as part of *Our City. Our Budget. Our Future.* is continued.
- Focus on what has changed over the past several months rather than a re-opening of the discussion about the approved 2012-2014 business plans and budgets.

Survey Results

Over 2800 people visited the micro site while the survey was open, the majority from direct traffic to calgary.ca/ourfuture. We also have a mobile app for this site, through which 488 citizens visited. 232 respondents completed the survey, many providing clear and specific comments. Highlights of the survey results are:

- Slightly more than three-quarters of respondents feel The City is doing a good job of providing the services it said it would provide in the 2012 - 2014 Business Plans and Budget.
- Respondents who do not think The City is doing a good job of providing the services reported that The City could improve in this area by not over-spending and/or improperly spending money, providing more funding/support to CPS, Fire and EMS, and improving Transportation planning.
- Two-thirds of respondents reported that since the 2012 - 2014 Business Plans and Budget were approved last November, nothing changed or shifted that The City should consider for the adjustments process and in their priorities.
- Among the respondents, the most preferred way of informing them is via the “Our City. Our Budget. Our Future.” website. The City of Calgary’s Calgary City News Blog (www.calgarycitynews.com) is the second most preferred medium.

Many respondents provided comments on what has potentially changed or shifted since Council deliberations in 2011 along with their ideas on what priorities The City should focus on. Those unaltered responses are in Appendix A of the survey results report, and are sorted into categories of general, specific departmental comments, and employees. Generally, respondents commented about such external factors as the new Provincial government, recreation centre funding, a Calgary economy that is heating up, and that additional services will be need for the influx of people moving to Calgary for work.

How The City will use the 2013 & 2014 Adjustments Engagement results

The information contained in this report is being provided to citizens via the calgary.ca/ourfuture micro site. It is also being sent to the Mayor and members of Council, the City of Calgary City Manager and General Managers, and is also being placed on myCity for internal use by business planners, departmental adjustments process leads, and all City of Calgary staff who are part of the adjustments process or simply interested in the results and go forwards of this engagement.

This information is being provided at this time so that it can inform any adjustments being proposed by the departments of The City of Calgary. The City will report back to citizens on how the information gathered as part of this engagement process informed and was utilized when making their adjustments recommendations, and if the information gathered was not able to inform the process that will be shared as well.

Phase II and Phase III Adjustments Engagement

Communication and engagement plans are being developed for Phase II and Phase III of the Adjustments engagement process, and will be fully completed over the summer of 2012. Analysis of the engagement information, web trends and metrics, comments and feedback will be done to aid in the development of further engagement.

The proposed adjustments and explanations will be posted on calgary.ca/ourfuture in 2012 November in a manner similar to what was used during BPBC3. Comment boxes on the site will remain active and monitored, and we will work to provide stronger links and information to financial and project information. We will also conduct another survey in November to be used to give Calgary City Council further information from Calgarians on the proposed adjustment recommendations that may help Council inform their decision during deliberations.

During Phase II, multiple marketing tactics will again be used to invite Calgarians to participate in the process, along with a Report to Calgarians, traditional media, social media and further interaction with community groups.

Once Council deliberations are complete, we will post to calgary.ca/ourfuture the 2013 – 2014 Approved Adjustments to complete Phase III.

2013 & 2014 Business Plans and Budget Adjustments Survey Report

Phase 1 - June 2012

Introduction

In preparation for the 2013 & 2014 Business Plans and Budget Adjustments process, the Chief Financial Officer's Department (CFOD) conducted an online survey from June 12 until June 30, 2012. The survey was conducted using the online survey tool, *FluidSurveys*, with a link being posted on a City website dedicated to the topic of the 2013 & 2014 Business Plans and Budget Adjustments process. The survey was open to anyone, including both citizens and City employees, interested in participating.

As a result of the "open link" survey methodology used (as opposed to a random sample methodology), the survey results are not representative of the Calgary population nor are they representative of any population subgroups. The results are indicative only of the respondents who chose to complete the online survey.

Results

Q1a. Have you looked for information about The City of Calgary's 2012 – 2014 Business Plans and Budget and/or the 2013 & 2014 Budget Adjustments Process? *(asked of all 232 respondents)*

- A slight majority of respondents have looked for information about The City's 2012 – 2014 Business Plans and Budget and/or the 2013 & 2014 Budget Adjustments Process.

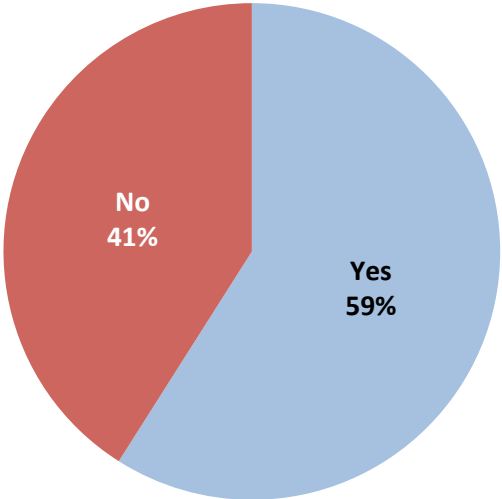

Q1b. Did you find everything you were hoping to find? (asked of the 137 respondents who looked for the information)

- Of those who looked for information, three-quarters found everything they were hoping to find.

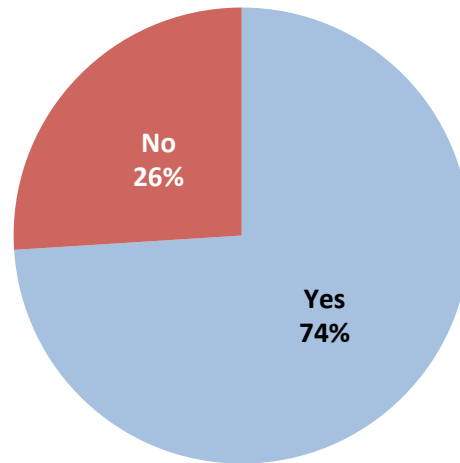

Q1c. What other information were you hoping to find? (asked of the 35 respondents who did not find everything they were hoping to find)
unprompted, open-ended responses

- Those who didn't find what they were looking for were mainly hoping to find more specific details about budget cuts, surpluses, etc. and/or more information about Transportation planning (i.e., roads, buses and LRT).

	% respondents
Specific details (general, cuts, surpluses, shortages, long-range growth priorities, targets, a spreadsheet)	57%
Transportation planning information/details (roads, bus & LRT routes)	26%
Police & EMS planning and spending information	11%
UEP information	9%
DBA/Infrastructure planning and spending information	3%
Parks information	3%
Other	6%

Note: Multiple mentions allowed; therefore, percentages do not add to 100%

Sample comments from respondents:

“More transparent information about forecast spend and cost overruns on major capital projects like the West LRT and Airport Tunnel.”

“I would like to be able to see what business units are over budget and which are under budget and why.”

“The 2012 – 14 Budget documents are pretty much line items with very little detail.”

“A breakdown of how all of our revenues are generated from each division and a breakdown of expenses from each individual division so that we can see where all of our funds are being spent.”

Q1d. Why have you not looked for information about The City of Calgary’s 2012 – 2014 Business Plans and Budget and/or the 2013 & 2014 Budget Adjustments Process? *n=95 (asked of the 95 respondents who did not look for the information)*
 unprompted, open-ended responses

- Respondents who didn’t look for the information tended to cite reasons such as not having enough time to do so, not being interested in doing so, or not realizing that the information was available.

	% respondents
Too busy/not enough time/haven't thought about it	21%
Not interested/don't care	20%
Wasn't aware it was available	15%
It won't matter/it won't change anything	9%
Don't know where to find the information	9%
Already heard about it/familiar with it	7%
Don't feel the need to because The City is doing an acceptable job/I trust The City	4%
It's too complicated/difficult to understand	3%
Too much to read	3%
Don't feel like I need to (unspecified)	3%
Other	11%

Note: Multiple mentions allowed; therefore, percentages do not add to 100%

Sample comments from respondents:

“I’m pleased with the Council priorities, budget and the leadership that is being provided by the Mayor.”

“Not a priority in my life right now. Cumbersome to find specific information.”

“No time in the day for this.”

“Have not thought to. Not that interested.”

“I did not know it was available to me . . . “

“. . . what does it matter? They will do what they are going to do without me.”

“I have no control over it so I have little to no interest in it.”

Q2a. Do you feel The City is doing a good job of providing the services it said it would provide in the 2012 - 2014 Business Plans and Budget? (asked of all 232 respondents)

- Slightly more than three-quarters of respondents feel The City is doing a good job of providing the services it said it would provide in the 2012 - 2014 Business Plans and Budget.

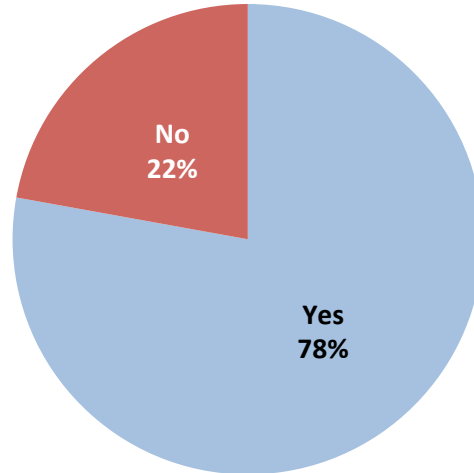

Q2b. What improvements could The City make in providing those services outlined in the 2012 – 2014 Business Plans and Budget? (asked of the 52 respondents who do not think The City is doing a good job providing the services it said it would) unprompted, open-ended responses

- Respondents who do not think The City is doing a good job of providing the services reported that The City could improve in this area by not over-spending and/or improperly spending money, providing more funding/support to CPS, Fire and EMS, and improving Transportation planning.

	% respondents
Quit over-spending/mis-spending (general)	25%
More funding/support for CPS, EMS & Fire	23%
Better Transportation planning	17%
Internal City improvements (e.g., technology, training, employee retention, employee benefits, communication)	10%
Quit over-spending/mis-spending on Transportation (e.g., bridges, cycling lanes, Airport Tunnel)	8%
More funding/support for Parks	6%
Listen to Calgarians	6%
Quit over-spending/mis-spending on Transit (LRT)	4%
Quit over-spending on public artwork	4%
More funding/support for roads	2%
More funding/support for Transit	2%
More funding/support for Bylaw	2%
More funding/support for recreation centres	2%
Other	12%

Note: Multiple mentions allowed; therefore, percentages do not add to 100%

Sample comments from respondents:

“Need to stop going over budget on projects, Peace Bridge, West LRT and soon to be the Airport Tunnel.”

“Stop over-spending. It seems everything – LRT, artwork, bridges – are all over budget.”

“More funding to emergency services, specifically policing. As a Calgarian, my quality of life, and that of my children, within the city is directly dependent on how safe we feel within our community. The police are doing a great job right now but as the city grows, security has started to erode somewhat.”

“Improving Emergency Services staffing deployment levels (growth and attrition). Expedite emergency service infrastructure projects and upgrades. Proactively address required staffing for emergency response (Fire, Police) and non-emergency (adequate Bylaw resources).”

“Calgary Transit does not provide the best service that it could, given the size of the city. I haven’t seen the type of service that is outlined in the plan.”

“Staying up [to date] with technology and training on the systems we work with.”

Q3a. Since the 2012 - 2014 Business Plans and Budget were approved last November, has anything changed or shifted that The City should consider for the adjustments process and in their priorities?
(asked of all 232 respondents)

- Two-thirds of respondents reported that since the 2012 - 2014 Business Plans and Budget were approved last November, nothing changed or shifted that The City should consider for the adjustments process and in their priorities.

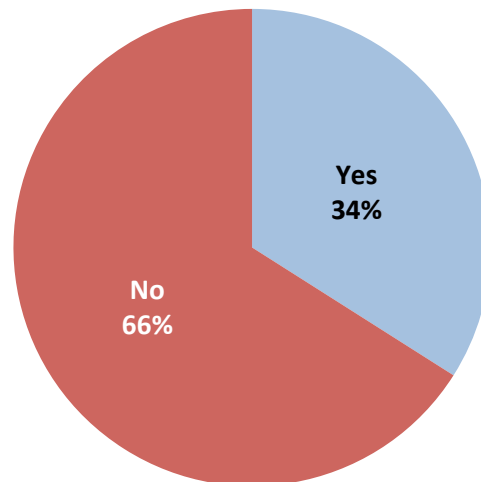

Sample comments from respondents: (all verbatim responses are in Appendix A)

“World economy has shifted, this dominos down to everyone placing more pressure on those already considered at risk and furthers limits them from participating at any sort of level in this city.”

"- addition of curb side pickup of compost.- there's been no use of zero-balance budgeting.- we should not be landscaping St. Patrick's Island, as it is outside of the TIFF zone."

"Lack of funding from federal and provincial govt. _ policing, leisure centres, etc."

"The projected growth factor of the population and housing projects should raise the importance of emergency services in terms of addressing response times and adequate resources/deployment."

"The hiring of the new City Planner will change how we look at population density."

Q4a. Would you like The City to inform you about the upcoming 2013 & 2014 Business Plans and Budget Adjustments in November? *(asked of all 232 respondents)*

- A slight majority would like The City to inform them about the upcoming 2013 & 2014 Business Plans and Budget Adjustments in November.
-

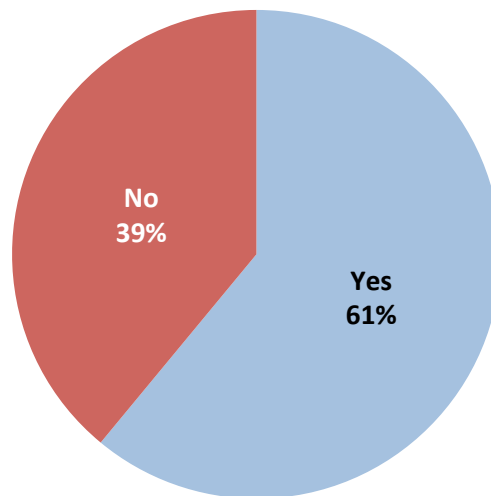

Q4b. How would you like The City to provide you with that information? *(asked of the 142 respondents who would like The City to provide them with the information)*

- Among these respondents, the most preferred way of informing them is via the "Our City. Our Budget. Our Future." website. The City of Calgary's Calgary City News Blog (www.calgarycitynews.com) is the second most preferred medium.

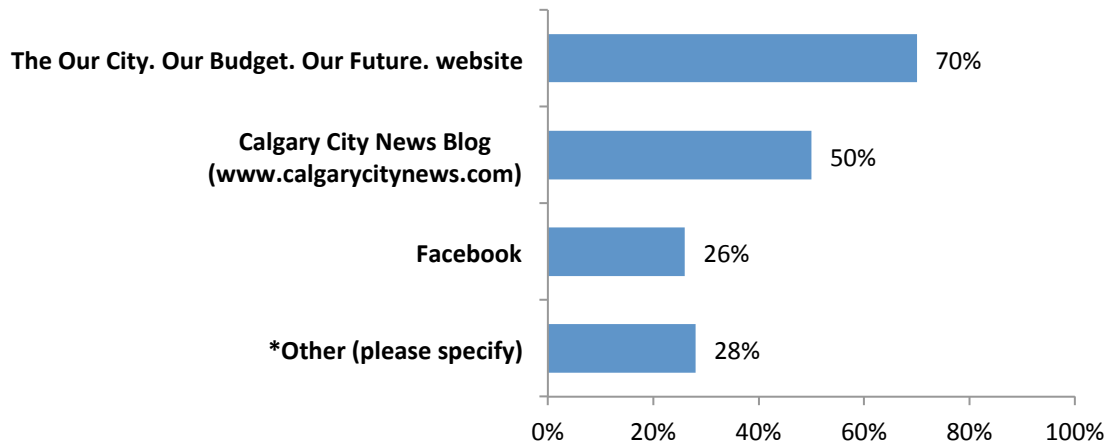

Note: Multiple mentions allowed; therefore, percentages do not add to 100%

*For specific responses to "Other (please specify), please refer to the following table.

Other ways respondents would like The City to provide them with information about the upcoming 2013 & 2014 Business Plans and Budget Adjustments (asked of the 40 respondents who selected 'Other' for the question "How would you like The City to provide you with that information?")

unprompted, open-ended responses

	% respondents
Newspapers	20%
Media/news release (unspecified)	15%
Email (unspecified)	15%
Flyer/brochure/leaflet/mail	13%
TV	13%
Twitter	10%
Employee email	10%
Calgary.ca	5%
Radio	3%
Intranet	3%
Website (unspecified)	3%
Other	10%

Note: Multiple mentions allowed; therefore, percentages do not add to 100%

Q4c. Why do you not want to be informed about the upcoming 2013 & 2014 Business Plans and Budget Adjustments? (asked of the 90 respondents who do not want to be informed)

unprompted, open-ended responses

- Of those who do not want to be informed, the most mentioned reason for not being interested in being informed about the budget adjustments by The City is that they will find the information on their own and/or find it somewhere else (e.g., through their work at The City).

	% respondents
Will find out about it on my own/from somewhere else	41%
Not interested	13%
It won't make a difference anyway	10%
Too busy	6%
Other	7%

Note: Multiple mentions allowed; therefore, percentages do not add to 100%

Sample comments from respondents:

"Information is readily available if I need it. I don't need to receive a personal notice/email/update."

"I'll seek it out myself."

"No need to inform me personally as long as there is information on calgary.ca that I can access on my own."

"If we want to know, we can look. . . sending it out to the masses is a waste of money."

"The City government does not care what I think anyways. What will I be able to do?"

Q5a. Would you like to continue to provide The City with your comments and feedback on the proposed budget adjustments? *(asked of all 232 respondents)*

- The majority of respondents would like to continue to provide The City with their comments and feedback on the proposed budget adjustments.

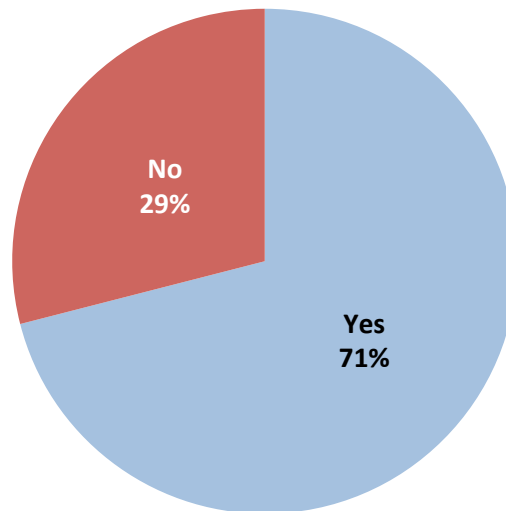

Q5b. How would you like to continue to provide The City with your comments and feedback on the proposed budget adjustments? (asked of the 165 respondents who would like to continue to provide The City with their comments and feedback)

- Respondents would like to provide their comments and feedback on the proposed budget adjustments through the use of online comments boxes and, to a lesser extent, via the Calgary City News Blog (www.calgarycitynews.com).

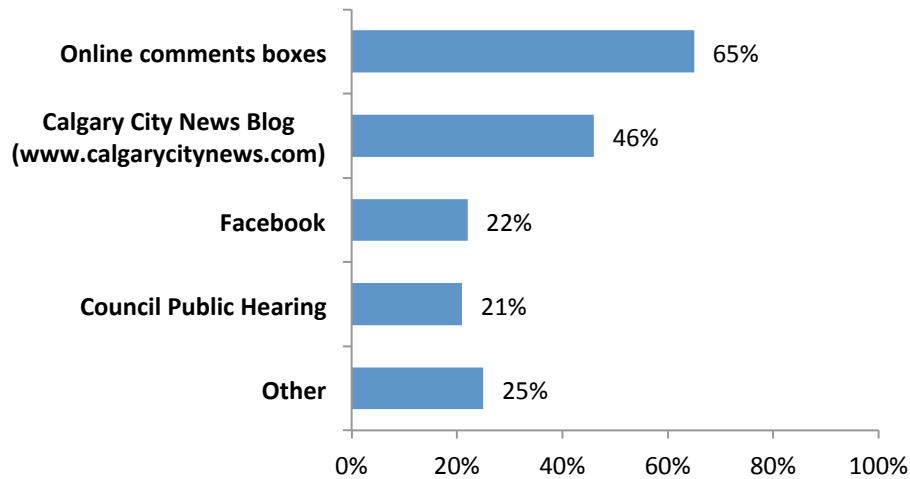

Note: Multiple mentions allowed; therefore, percentages do not add to 100%

Other ways respondents would like to continue to provide The City with their comments and feedback on the proposed budget adjustments n=41 (asked of the 41 respondents who selected “Other” for the question “How would you like to continue to provide The City with your comments and feedback on the proposed budget adjustments?”)

unprompted, open-ended responses

	% respondents
Surveys	51%
Calgary.ca	15%
Twitter	10%
Open houses/Town Halls/budget workshop	7%
Work (unspecified)	5%
Work email	5%
Email (unspecified)	2%
Other	10%

Note: Multiple mentions allowed; therefore, percentages do not add to 100%

Q5c. Why do you not want to continue to provide The City with your comments and feedback on the proposed budget adjustments? (asked of the 67 respondents who do not want to continue to provide their comments and feedback)

unprompted, open-ended responses

- Among those who do not want to continue to provide The City with their comments/feedback, the single most mentioned reason (by one-quarter of these respondents) is that their input won't matter anyway (i.e., no one listens, pays attention, follows-up). Approximately one-fifth do not feel informed enough to provide input and one-fifth are simply not interested.

	% respondents
No one listens/pays attention/follows-up/it doesn't matter	25%
Don't think I'm informed enough/haven't anything to add	12%
Not interested	10%
Too busy	6%
Trust The City/Administration	4%
Other	25%

Note: Multiple mentions allowed; therefore, percentages do not add to 100%

Sample comments from respondents:

"I believe The City is doing a great job with our relatively new Mayor Nenshi . . ."

"[I] don't feel The City listens anyhow – they have their own agenda."

"I don't believe that my comments and feedback have any value to the decision-makers."

"I don't feel that I have a thorough knowledge of the subject . . . therefore, I do not feel I can offer anything constructive."

Q6. Please feel free to share any other comments you have related to the upcoming 2013 & 2014 Business Plans and Budget Adjustments.

All verbatim responses are included in Appendix B.

Demographics

In which quadrant of The City do you reside?

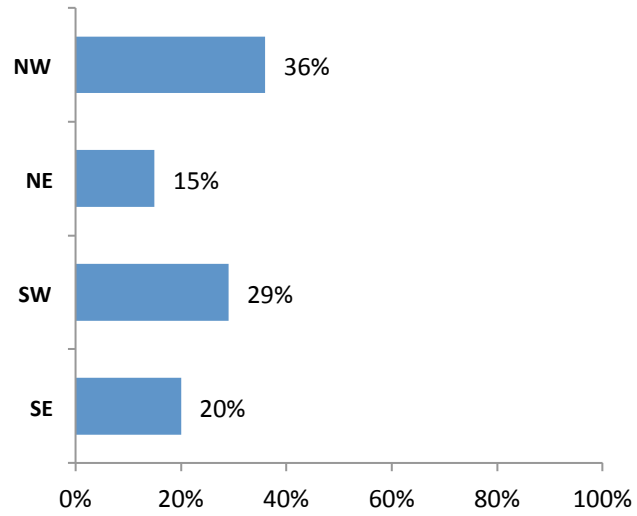

Are you male or female?

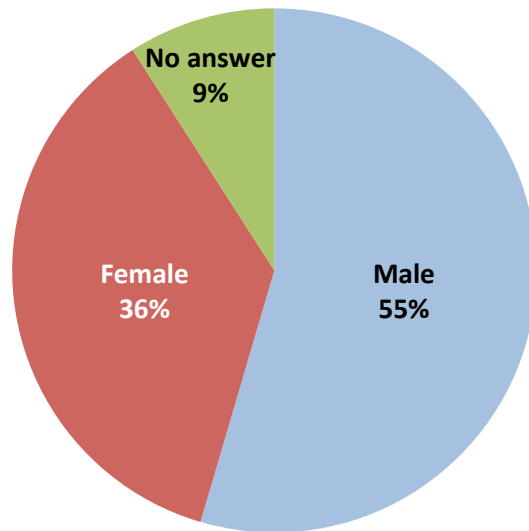

Which of the following categories best describes your age?

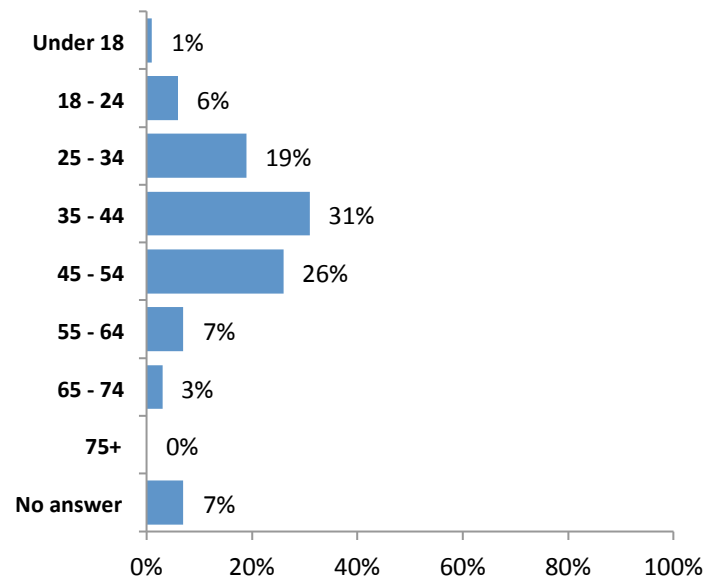

Appendix A

Q3b. What has changed or shifted and why? Please be as specific as possible.

General

"New provincial government - implications on provincial direction re: municipalities growth pressures beginning to grow in Alberta again - low unemployment, more construction, rising housing prices, etc."

"- addition of curb side pickup of compost.- there's been no use of zero-balance budgeting.- we should not be landscaping St. Patrick's Island, as it is outside of the TIFF zone."

"Since I originally filled out the survey, I have gained a great appreciation for The City's system of parks and pathways. In my opinion, further money should be provided to:1) Create sufficient links for an uninterrupted pathway from the far end of Bowness Park in the Northwest to downtown Calgary. Right now, there is a missing link through Shouldice Athletic Park (where I understand there is a proposed pathway) and a missing link parallel to 52nd Street NW between Home Road and Bowness Road, NW - an area that would be perfect for a barriered bike lane.2) Similarly, the gaps in the Southwest network between the Glenmore Reservoir and Downtown should be filled, though I confess that I am not familiar enough with that network to give a complete list.3) Further resources should be put into patrolling, maintaining, and clearing snow on the regional pathways. In particular, problems exist with bicyclists riding far in excess of the speed limit. East of Downtown and in the evenings, portions of the pathway become unfriendly, as they are too often utilized by drunken vagrants. I believe that people should be able to feel as safe on the pathways as they do in their own cars.4) I would also recommend maintenance work be performed on the Douglas Fir Trail."

"Roads maintenance, street lighting, and public artworks could benefit from better funding and/or assessment."

"The City should be mindful of larger economic forces. The City is not an island that is immune to other events happening in the global economy and financial markets."

"Stronger provincial government leadership with a different attitude and set of priorities; may be better or not. Electricity, natural gas futures and regulations. European financial/political crisis unresolved and deepening."

"There's new areas to live in and I don't see supporting services getting to them. I'm in Sagehill."

"1. The ballooning cost of the West Leg LRT.2. The potential for a rapidly expanding economy in Alberta / Calgary (oil sands development, US softening on Keystone pipeline position) in the near future coupled with the potential for the European economic crisis to have significant downward pressure on the price of oil.3. Changes to Employment Insurance that might increase interprovincial migration to Alberta."

"1) A new Premier and new government, may make certain funding assumptions more risky.2) Oil and gas jobs seem to be coming back. Were the growth forecasts accurate?"

"Police budget..always the same thing every time its negotiation time...stall tactics."

"Let's make sure Enmax gets ride of all above ground wires in a underground area let Woodbine. Why we have paid extra taxes for 25 years."

"Service needs. Population growth."

"Something on future planning on a new stadium or venue."

"The public art mish mash. Waffling about LRT parking fees. Increasingly regular C-train breakdowns that backup service everywhere."

"World economy has shifted, this dominos down to everyone placing more pressure on those already considered at risk and furthers limits them from participating at any sort of level in this city."

Corporate Administration

"I don't think that the allocations for certain infrastructure allocations are accurate. I also do not think that the city manager has accounted for where the funding is going."

"Things are just getting to expensive for the average family, we need to control all costs and spending. Artwork, bridges etc. should come second to ensuring Calgarians can afford to remain Calgarians."

"Property taxes - way too much!"

"Lack of funding from federal and provincial govt. _ policing, leisure centres, etc."

"Cost overruns."

"The price of crude oil has dropped off and natural gas futures are not looking good either. In a resource dependent province we have to keep our eyes open and realize that the money Calgary receives from the federal and provincial government may be on the decline in the near future."

"Stop the hidden taxes like local access fee on an enmax bill."

"Increased funding is required for the relief of the increasingly strained Finance/Financial Services Department. Constantly increasing heavy workloads, including the lack of vacation coverage, are reducing the quality and timeliness of completing financial and managerial reports. In some cases, important tasks and/or reports are not being completed due to limited human resources and/or budget resources. This consequently reduces an operational business unit's efficiency and its capability to achieve optimal performance."

Community Services & Protective Services

"Need more money for parks. Parks are essential to the quality of life in Calgary. But the parks and service levels are starting to deteriorate."

"When the city approved the budget they spent more money on cutting the grass then all of the fcsc spending."

"Need to find funds to keep our park infrastructure vibrant and maintained."

"Less focus on social programs.... programs for families and working Calgarians!!! And less for the lazy who just want hand outs."

"Please keep our city clean, as a good neighbour we all clean up our yards and take care of our weeds. A look at the city property and the city is a poor neighbour - wait till this years weed seeds over run us next year."

"The city has never looked worse than it does now. There are so many weeds it is embarrassing."

"I believe that having mandatory spending on art as part of new development projects, is an unreasonable waste of tax payers dollars. Any spending on art should have to be passed by vote in city council, on a case by case basis."

"Rec centers are important but I think we are starting to spend a disproportionate amount of money on them."

"I would like to see a little bit more emphasis on diversity - both internally within the City of Calgary employee base and externally in terms of supporting our diverse communities. The reason is that as the largest local employer and a public serving organization, we need to demonstrate accountability in serving all Calgarians, regardless of their income levels, geography, learning styles, physical or mental ability, age, gender, religion, race, colour or ethnicity. I know the City is doing a great job on the community side, but it needs to be written down and highlighted more often for all Calgarians to see and to support. We also need to be more proactive in attracting and retaining a talented diverse workforce if we want Calgary to be a magnet for talent."

"I was not aware that we spend so much on the arts, namely painting of utility boxes and downtown artwork. I feel this is frivolous spending in these times when there are other areas that are in need of more funding."

"Recreation centers in the south and the SE leg of the LRT needs to be expedited in order to minimize the traffic congestion on Deerfoot and other feeders."

"The loss of P3 funding for our new Rec centers was a major Blow to the City and we are extremely short of space for Recreational Activities already, and in our ever growing city this shortage is only going to get worse before it gets better. I believe this lack of Recreational Facilities needs to be addressed sooner rather than later."

"Less citizen facing projects were included. We need community services."

"The amount of cyclist on the roads this year has increased dramatically from last year, and safety is becoming a big issue. More funds need to be allocated to address this in a quick manner."

Emergency Services (Calgary Police Services, Calgary Fire Department, EMS)

"The Calgary Police Service has squandered the massive budget increase they were given (example: using a police helicopter to track a pair of shoplifters across the city), demonstrating that it was unnecessary. Transfer some or all of it to the chronically-underfunded transit system."

"Security on LRT and parks as well as policing - more and more incidents most likely due to the lack of security officers on the street. I hear that the police are without a contract and have been for over a year."

"I fully support the excellent work being conducted by CPS."

"City growth - need more police and fire staff."

"The projected growth factor of the population and housing projects should raise the importance of emergency services in terms of addressing response times and adequate resources/deployment."

"I think that the City has to ensure it continues to support the Police Service so that it continues to be a safe city. This includes the HAWC helicopter program as it has proven itself in it's worth."

"More money for police, it is needed."

"Money has been taken from Police training budgets. Training is important in different investigative techniques so as to keep up to date with current best practice."

"More people, more crime, more drugs, more fights, more drunks, more intolerance and the courts are doing a lousy job. Need a bigger jail and need to go back to locking people up."

"The police budget should not be continued to be cut and drained. This causes stress on a resource that is important to public safety."

"I am concerned that the Mayor keeps questioning the way the Police run. There is a reason for the Police Commission and that is to keep the elected officials from getting too involved - or interfering."

"Maintain a focus on the police budget ensuring a safe and secure city."

"Increase emergency services budget."

"Find people that want to be a cop & are prepared to do the job that they swore an oath to and get rid of the dead wood that are just waiting around for a tax payer pension."

Planning, Development & Assessment

"There seems to be some trouble in the assessment office. Seems the staff are either unhappy, or something is going on, always getting bounced around."

"The hiring of the new City Planner will change how we look at population density."

"Fire everyone in the planning department and start again with new hires. We hear from contractors and trades people ALL THE TIME that permits and small developments are murderous in terms of red tape and craziness at City Hall. The bylaws need to be overhauled and clarified. If the food trucks can be figured out by [one person] single handedly while all previous efforts were mangled and denied due to fiefdom stupidnesses, perhaps you need to start again. Get rid of the people whose role has been to impede improvements and citizen engagement/participation and let's get on with things. I want to put a bike shelter in my front yard but can't for some stupid bylaw reason - please, fire everyone there and start again."

Transportation

"Calgary economy has heated up which will cause demand for transit to increase."

"We should not spend the un used snow budget on other areas when there is not a lot of snow. Overtime hours add up fast when the snow crews work. What is not used in each year or each area of the budget should be carried over to next year in case is worse."

"A lot of the population lives in suburbs, transit is absolutely horrific in many areas - this NEEDS to be a priority if the city wants to reduce the amount of people driving."

"The provincial talks on roads such as Deerfoot, if they are handed back to the city has this been factored into the budget process."

"It seems people are wanting a healthier lifestyle and more people appear to be cycling to work. You have made great strides in the bike pathways (pathways alongside deerfoot enhanced - thanks). Need more in the north and going east - west. Cuts down on vehicle traffic and improves health general population at the same time."

"The west leg of the LRT is poorly designed. The city also needs to have a west east leg of the LRT that does not cut through the downtown core."

"The west leg of the LRT is poorly designed. The city also needs to have a west east leg of the LRT that does not cut through the downtown core. The status of the SW Ring road."

"Transit use is climbing at rates greater than I believe the city has anticipated. This is a very good thing, but the city needs to dedicate greater funds to Calgary Transit for more transit hours and to speed up planned upgrades to transit infrastructure."

"South west ring road delays."

"The "tunnel" at the airport in the NE is costing us too much. We should be spending that money on increased transit options ... c-train lines, putting the 25th ave and Macleod train below ground, getting green carts going faster (how embarrassing that we're so far behind) or any of a number of significantly more worthy initiatives ..."

"why SPEND MORE MONEY ON SNOW REMOVAL? HEY DUMMY YOU LIVE IN CANADA AND CALGARY TO BOOT, WHICH IS CLOSE TO MOUNTAINS...MORE SNOW! THE CITY WAS JUST FINE FOR THE LAST 30 YEARS AND NOW ALL OF A SUDDEN WE NEED MORE SNOW REMOVAL. WE ARE SHIFTED TO SPENDING MORE MONEY ON ART IN THE CITY WHICH MIGHT LOOK NICE BUT IS NOT FUNCTIONAL IN A BUDGET CRUNCH."

"The snow removal budget is a joke, we run 'over' every year? Last year was a 'light' year for snow, yet once again we are over? The department is completely mis-managed, we are out plowing at 8 am, when the snow is melting by noon....and on and on. Also the police budget needs to be increased, in order to keep with the growing city, and to keep us inline with other major cities....why is our ratio of officers to citizens so out of line?"

"Roads infrastructure. Some are falling apart. Too much focus on social needs of the few rather than the whole. I agree with assisting people with a hand up not a hand out (there are many who are taking advantage of this system and those that really need are falling through the cracks). Need to re-think our social giving policies."

"Calgary transit should be provided more funding to increase route frequency and more drivers overall."

"The amount of cyclist on the roads this year has increased dramatically from last year, and safety is becoming a big issue. More funds need to be allocated to address this in a quick manner."

Employees

"Once again there was talk about setting up a fitness room for the employees in the Municipal Building and once again it was nixed. I realize that council folded when the citizens of Calgary were incensed that employee's would have access to a fitness centre. What the citizens do not know, is that a lot of area offices, i.e. Water Centre, the N.E. office where 911 operators are, have fitness rooms available to them. As an employer I would hope that council will go ahead with a fitness facility within the municipal building. Now that the cafeteria will be closing that would be the perfect place for it. Remember, that we as employee's are also taxpayers, a lot of employee's already use the WOW fitness classes, they could be in this empty cafeteria space as well as fitness equipment. It would be a step in the right direction, the City will be employing more and more young people in the near future and it would be an attractive feature of employment. I am not asking for it to be free, but I believe it is free for other city of Calgary employees in those areas that have the fitness centres already available to them. As a supervisor within the City, what I have noticed, is that the employee's who do the WOW fitness classes take more than the hour allotted, with the length of the class and then having to change in washrooms and wash up at sinks. If there was a workout facility, you could ask the staff to manage their time better, and maybe make the workout classes after work to avoid the 1.5 hours of lunch that the staff take when they are going to the classes over their lunch hour. It would be a win/win situation. I am hoping that council takes another look at this situation, regards!"

"Nothing specific has changed, however employee engagement is poor and results in significant inefficiencies which, if addressed, could bring about large operational cost savings. We don't seem to make the connection very well between employee engagement and effectiveness relative to the bottom line. Nothing new."

"First, I think the "budget tightening" that has gone on was necessary as spending was a little out of control. Most importantly, however, I think the "change" in terms of the City's view towards training is faulty and will cost the City millions \$ in the future. It appears that "training" is a bad word in the Corporation now - it certainly seems that way in the Police Service. As a trainer I will be the first to say that there was a ton of inefficient, wasteful, unproductive training that has gone on. But to cut out training altogether is not the answer. Cut out the wasteful stuff and fix the required stuff and keep delivering it. The CORPORATION is PEOPLE. Training is an investment in YOUR PEOPLE. And you can not go wrong by investing in QUALITY training for your people."

"Our work place is worse then a prison camp right now and getting worse bye the day."

Appendix B

Q6. Please feel free to share any other comments you have related to the upcoming 2013 & 2014 Business Plans and Budget Adjustments.

General

"I'm a little concerned with the wait times for non-emergency services. I reported a street light staying on 24 x 7 and it took approx 4 months before anyone came to fix it. I also called in a noise complaint to the CPS and had to wait hours for someone to attend. Not so much fun at 2:00am when you are trying to sleep!!"

"Keep up the great work...keep spending!!!!"

"The city spends more money on the bike lanes downtown than any available funding request to look after the youth of our society."

"Nenshi needs to become more practical and less confrontational with police."

"Always like to see more funding for police, social program, roads."

Corporate Administration

"City council is definitely on the right track with its budgeting process. Just remember that the loudest voices do not represent the majority. Many Calgarians are willing to pay for better service."

"I like the fact the City is being cautious with increasing expenditures in this period of economic uncertainty. Reality check however for all involved in this process: there is only one taxpayer. Whether the funding comes from property, provincial or federal levels the same taxpayer funds all 3 levels & any increases in one level without a corresponding decrease in another level means less income left over for the taxpayer. While it would be nice to have a couple of clones who pay my provincial & federal taxes while I pay only the municipal taxes, this is not reality. However, when listening to interviews of various public figures including economists from various think tanks the language used seems to imply that money from other levels of government are somehow not coming out of the taxpayer pocket. Misleading & untrue. Add in the belief that a taxpayer in Cochrane, Airdrie, Okotoks is NOT funding Calgary expenditures & vice versa - also untrue. If we are receiving or paying towards any provincial or federal funds, we are paying something towards every public service provided in Canada no matter where we live."

"More scrutiny needs to be done of public spending."

"Several Business Units, such as Calgary Transit, are producing significant favourable financial variances that would permit feasible budget transfers to the Finance Department."

"STOP SPENDING MONEY ON NICE TO HAVE ART AND BRIDGES AND THE ZOO ISLAND REPAIRS. RIGHT NOW FOCUS ON THE PRIORITY ASPECTS LIKE POLICE FIRE THE STREETS CTRAIN(NOT THE SPACE AGE CTRAIN WASTE OF MONEY SPENT ON THE WEST EXPANSION. PLAIN AND SIMPLE"

Corporate Services

"I am very pleased to see the high level of citizen engagement and collaboration in the major decisions that are coming up (e.g. Parks vision, future public library). Excellent job!!! Please keep this up. By staying in touch with the public, you are encouraging them to also 'own up' to their responsibility as a caring citizen. If you walk the talk, you will have many supporters."

"I think sharing as much information as possible with the public is key. Sharing in, easy to understand, and highly accessible formats is key. I am huge fan of Mayor Nenshi's use of Facebook and the use of his Herald columns. Government needs to remain relevant and open to the population so that people don't see the government as a separate entity that they have no power to influence. When government is open and accountable and is not afraid to show that it can makes mistakes then we have an openness and an ability to do bigger and better things."

"How is it that the Calgary Blog and Facebook are preferred over the City of Calgary website?"

"Very nice initiative that should be the de facto role model for all Canadian cities! This team has done more in the past two years than I've ever seen before to foster citizen engagement; I'm looking forward to the next round of adjustment surveys! Nenshi, you've made a name for yourself by not only outlining a plan but DOING the plan! Keep on it; pedal to the metal!"

Community Services & Protective Services

"It is our Cities 100 Stampede and out city streets and "grass areas" all are over run by weeds. Come into Calgary on any road and see what a crappy job we are doing in trying to maintain a clean weed control city - NOT. If I let my yard go like that my neighbours and friends would all be pissed off at me. Come on Calgary clean up!"

"Revamp the 'art' requirement with all new contracts.....its nice to have an art piece with all new projects, but the amount is ridiculous...."

"High priority is safety (police), infrastructure (roads, pathways etc.) and family related issues (sport facilities and family programs like swimming, hockey, soccer programs)."

Planning, Development & Assessment

"Get rid of the the red tape for property develop permits. adding a roof to a existing balcony should note a federal case? lets get back regular building permits."

Transportation

"1) I am concerned about the Snow and Ice Control funding. Last winter wasn't all that bad. What happens if we get a particularly snowy winter. 2) In the Business Plan and Budget, Parks identifies efficiencies and subsequent savings in utilizing their vehicle fleet. There are other Business Units who should be looking at this as well."

"I briefly looked at the transportation section of it and everything seems reasonable. No overall change in cost is good and smart."

"I have a concern regarding our City Roads snow removal and sanding department annual budget. It is my understanding that they are provided a specific operating budget for the year. If, as in this past year, the snowfall amount was less than in previous years, the department would not maintain or increase their budget unless all the resources are used to justify the given amount. I'm of the belief that this must be the case as I have witnessed on numerous occasions snow removal and sanding trucks on our city streets operating at times when it is laughable at the amount of snow on the road or they remove a layer of snow on packed snow causing a glistening sheen of ice making the road more dangerous than prior to the snowfall. If the committee is looking at plans & adjustments, maybe it should consider a floating budget for such areas as snow removal. Some years may use more funds than others, but if there's a surplus one season it shouldn't affect the budget the following year. Commonsense dictates that snow removal vehicles and equipment should be used as required, not because the budget needs to be used up to justify funding for next year."

"Lived in City only three years and have seen constant improvements with the road system & bike paths."

"Public transit needs to be bumped up. Buses usually overflowing. More express buses (i.e. route 64) needed. Daily office commuters downtown Calgary find using the milk run routes cumbersome and time consuming so take the car instead (i.e. route 3)."

"Calgary Transit has taken a couple of years and spent millions of dollars to introduce a very simple smart card payment system that's been in use - generally unchanged - around the world for decades. That's just stupid! Smart card readers were an available option on the very first c-trains purchased in the 1980s."

"It would be great to have more information about the proposed LRT and road projects. I can never find enough info about these issues on line. LRT issues are a major one for most Calgarians as a cheaper way to get to work is a must for most people."

"Transit points to the large percentage of their operating budget coming from user fees, rather than the public coffer, as a sign of efficiency, but what this really shows is how ridiculously underfunded they are."

"Meanwhile the Calgary Police Service has more money than they know what to do with. Stop playing politics and fund what needs to be funded!"

"Transit should be a priority in both inner city and the suburbs. I would love to stop driving in Calgary and start taking transit if it is more effective."

"Keep to the priorities of running the City. Our tendency is to beautify things that in essence do not matter; i.e.. the LRT line in the southwest. Do not know why this is such a priority at almost 10 million?"

"Public safety and active transportation are noted as critical priorities of the proposed budget and CTP. With the drastic increase in the amount of cyclist on the roads, more funds need to be allocated to addressing safety through the creation of additional bike lanes. The proposed expenditures for roads can be decreased to accommodate this as it is the lowest priority in the CTP."

"High priority is safety (police), infrastructure (roads, pathways etc.) and family related issues (sport facilities and family programs like swimming, hockey, soccer programs)."

Utilities & Environmental Protection

“Encouraged to see the blue bins started.”

Emergency Services (Calgary Police Services, Calgary Fire Department, EMS)

“High priority is safety (police), infrastructure (roads, pathways etc.) and family related issues (sport facilities and family programs like swimming, hockey, soccer programs).”

“Money for police is important.”

“Please support our police to continue their suppression of crime.”

“Do not give yourself hefty pay rises then argue about the emergency service pay increases. These should not take two years to sort out. Greatest city in North America with one of the lowest crime rates and about 500 police officers less than Calgary should have. Invest in the future, do not risk burn out.”

“Quit cutting and analyzing our police services. They have helped our city tremendously and it shows. When I have people visit from out of town, they are amazed how safe they feel in our city. The police do a good job and should start to be rewarded for it, not always under a fine microscope. It seems like this is the most common theme in media..ENOUGH!”

“We have one of the lowest police officer to population ratios in the country... imagine what we could accomplish if we were on par or even close to it.”

“I appreciate [the] city makes the well being and safety of citizens on fore front by supporting the Calgary Police Services.”

“It’s funny how City counsel approves a significant raise for them selves but will not allow the same for the police who have been without a contract for 1.5 yrs.

“Audit CPS”

“1) Adjust Public Safety Communications, and give the police, fire and ambulance services THEIR OWN individual dispatch centres back. Shut down the amalgamated PSC organization. 2)Stop charging increases in waste removal (i.e.. the black bins). 3) have an accurate audit BEFORE you write the budget. 4) Stop building bridges to nowhere. 5)Cut politicians salaries. 6) Only increase taxes if there is a confirmed budgetary deficit. 7) If possible, try to allocate more funding for emergency services -if necessary, get money from the Province.”

“Do not cut budgets from essential city services such as Police, Fire, EMS etc. There are other area's that can be cut if needed.”

“Leave essential service budgets alone, let the fire department do their job, let EMS do their job, let CPS do their job. Take a fine look at the Public Safety Centre (PSC) and do a review of their practices. See how they are fiscally irresponsible, a safety hazard and failure. That should be a place to scrutinize the budget.”

“We all support the emergency services and the excellent way they support and help our city. They all deserve whatever pay raise the city approves; and arguably more.”

“Fire service is already using the City of Calgary Newsroom as a tool of advocating for their silly sprinkler proposals.”

Employees

“In the budget it mentions about the aging workforce, What is the City of Calgary planning to get younger people into the workforce. Kids out of high school have enthusiasm yet there aren't that many TRUE 'entry-level' positions within the workforce unless you want to work at Tim's. Do we even have a plan to get these kids working and finding life long careers???”

“Proactively address staffing levels with the expected projected growth versus implementation after the fact (playing catch up).”

Appendix C

Survey questions (available on calgary.ca June 12 – 30, 2012)

Note to readers: Text in square brackets within the survey is programming notes only and was not shown to respondents.

The City of Calgary is beginning the 2013 & 2014 business plans and budget adjustments and would like to hear your opinions. Please take a few minutes to complete this survey. Please be assured your responses are confidential and cannot be attributed to any particular individual.

The information from this survey is collected under the authority of the Freedom of Information and Protection of Privacy Act, Section 33(c) and is used to inform The City of Calgary's 2013 & 2014 proposed budget adjustments by Administration and City Council deliberations.

If you have any questions about this survey, please phone The City at 3-1-1 and refer to the "Budget Adjustments Survey".

1a. Have you looked for information about The City of Calgary's [2012 – 2014 Business Plans and Budget](#) and/or the [2013 & 2014 Budget Adjustments Process](#)?

Yes

No

[IF "YES" IN Q1a, ASK Q1b; OTHERWISE SKIP TO Q1d]

1b. Did you find everything you were hoping to find?

Yes

No

[IF "NO" IN Q1b, ASK Q1c; OTHERWISE SKIP TO Q2a]

1c. What other information were you hoping to find?

Please be as specific as possible.

1d. Why have you not looked for information about The City of Calgary's 2012 – 2014 Business Plans and Budget Adjustments Process?

2a. Do you feel The City is doing a good job of providing the services it said it would provide in the [2012 – 2014 Business Plans and Budget](#)?

Yes

No

[IF "NO" IN Q2a, ASK Q2b; OTHERWISE SKIP TO Q3a]

2b. What improvements could The City make in providing those services outlined in the 2012 – 2014 Business Plans and Budget?

Please be as specific as possible.

3a. Since the 2012 – 2014 Business Plans and Budget were approved last November, has anything changed or shifted that The City should consider for the adjustments process and in their priorities?

Yes

No

[IF “YES” IN Q3a, ASK Q3b; OTHERWISE SKIP TO Q4a]

3b. What has changed or shifted and why?

Please be as specific as possible.

4a. Would you like The City to inform you about the upcoming 2013 & 2014 Business Plans and Budget Adjustments in November?

Yes

No

[IF “YES” IN Q4a, ASK Q4b; OTHERWISE SKIP TO Q4c]

4b. How would you like The City to provide you with that information?

Please select all that apply.

[RANDOMIZE; MULTIPLE MENTION]

The Our City. Our Budget. Our Future. website

Facebook

Calgary City News Blog (www.calgarycitynews.com)

Other (please specify):

[IF “NO” IN Q4a, ASK Q4c; OTHERWISE SKIP TO Q5a]

4c. Why do you not want to be informed about the upcoming 2013 & 2014 Business Plans and Adjustments?

5a. Would you like to continue to provide The City with your comments and feedback on the proposed budget adjustments?

Yes

No

[IF “YES” IN Q5a, ASK Q5b; OTHERWISE SKIP TO Q6]

5b. How would you like to continue to provide The City with your comments and feedback on the proposed budget adjustments?

Please select all that apply.

[RANDOMIZE; MULTIPLE MENTION]

Online comments boxes

Council Public Hearing

Facebook

Calgary City News Blog (www.calgarycitynews.com)

Other (please specify):

[IF “NO” IN Q5a, ASK Q5c; OTHERWISE SKIP TO Q6]

5c. Why do you not want to continue to provide The City with your comments and feedback on the proposed budget adjustments?

6. Please feel free to share any other comments you have related to the upcoming 2013 & 2014 Business Plans and Budget Adjustments:

The last few questions are for the purpose of helping us to group responses and sort the information we collect in this survey. All responses will be held in strict confidence and cannot be attributed to any particular individual.

7. In which quadrant of the city do you reside?

NW
NE
SW
SE

8. Are you . . .

Male
Female
Prefer not to answer

9. Which of the following categories best describes your age?

Under 18
18 – 24
25 – 34
35 – 44
45 – 54
55 – 64
65 – 74
75+
Prefer not to answer

Thank you for taking the time to complete this survey. The City of Calgary appreciates your input.

2013 & 2014 Business Plans and Budget Adjustments Engagement Phase 1 - June 2012

Comments from the Comment Boxes on calgary.ca/ourfuture

The pages these comments were taken from are listed with the specific comment(s) below, verbatim from the micro site. All comment boxes are still open and will continue to be throughout the Adjustments process.

Council's Fiscal Plan comments

all I see is general statements, so not much to comment on

Transportation comments

Great commitments here for the transportation sector! I like the investments in corridors and activity centres! Let's create a more livable city!

UEP comments

These goals and directions are a little vague and wishy-washy. I would like to see some more concrete commitments to, for instance, urban agriculture, curb-side composting, reductions of green-house gas emissions from city operations, etc.

Your Property and Tax Dollars comments

This is why anything out of city hall is crap. RIGHT at the top of the page I will round to make life simple. \$400,000 dollar house pay 1400.00 in taxes. Now this is so far off. Based on these figures or stats then a \$800,000 dollar house should pay 2800.00 dollars. Now lets double that again 1.6million dollar house should pay \$5600.00 dollars correct. Then explain why a \$900,000 dollar house pays almost 6000.00 in taxes. Does anyone see what is wrong with this picture

It also says in the first sentence that your property tax dollars go to the province and the city. I imagine the \$1400 is just the portion that goes to the municipality, and the rest goes to the province. So, the \$1400 is not the total property tax, and is actually less than what a \$400,000 home would actually pay for property taxes total.

Let's Talk

Something does need to be done about the police, my mother was a victim of getting her purse stolen with all her credit card, and personal info in it and the cops just shrugged their shoulders and said who cares and even went so far as to say it was her fault...But I would also like to see maybe some more corner stores and shops pop up in the residential areas since the newer communities have not to much as far as commercial land. A person has to go quite the ways to find just a average corner store. I think with building more corner stores in the newer residential areas would also cut down on gas consumption by a huge amount and benefit people by having something close and convenient so they can rather use a bike or walk some place.

More funding and hiring cops that actually WANT to do the job they were hired to do instead of having some of the deadwood we do have who take great pleasure in further victimize the victims of crime, refuse evidence, claim evidence is lost and not about to go looking for it and are just waiting out their time until their tax payer retirement rolls around .

Ok what about the local access fee or hidden tax grab on the enmax bills. It should not be allowed or even considered since the city owns both enmax and the land we pay to have enmax access.

Good commitment to transparency!

No more regulation, slows inovation and prevents companies from operating at full capacity.

No more transit rate hikes, the lower/middle class has suffered enough in the past few years with inflation and wage stagnation.

(reply) They have to hike it at some point because they are building a new LRT station so the hike is like a thick tax to help pay for fixes within the transit system. I don't like the hike either with it but the money has to come from somewhere. And in Calgary..we are lucky to live here since we are about the least hit place in the world with the recession happening. I consider myself middle class and as long as you have one job, you can afford a transit ticket very easily...and getting a job is very easy here in Calgary.

Hello,

I am a grade 11 student from Crescent Heights!. I think our city is going to drowning under people who are not willing to pay taxes. I know a lot of business places who take cash without paying the tax to our government like some restaurants and local service man. If the government wants to have a sustainable Canada then have to hunt these people down as soon as possible. Now days some kids in classroom talk about methods to hide taxes when they start working. Government should setup a serious tax depenrment that hunt these kind of people down. Just look at this, billions of dollars are not been paid to the government and the next thing government does it cutting \$100 million from educational fund. Like what's wrong the government there are some people paying 80000 dollars in tax and some nothing still earning more than 200K I know more then ten business place in just saddlerdge that have in house business and the next thing you know they are running in 60,000 car by just giving facial service without any proof of purchase to customers. Like the government needs to set in before it's too late. it's kind of sad knowing that there are some homeless people that need this money but I can't do anything I wish I was the mayor I would make Calgary and Canada the best place to live.

(reply) Well you have to do what you have to do to make the most money these days.

More funding for the Arts

2013 & 2014 Business Plans and Budget Adjustments Engagement Phase 1 - June 2012

calgary.ca/ourfuture METRIC REPORT June 11 to July 9, 2012

The information contained in this metric report will aid The City in understanding how citizens and employees reached the micro site, where they spent their time, what search terms they used and other pertinent information. The results of the analysis will then guide The City as we move forward through Phases II and III of the 2013 & 2014 Adjustments Engagement.

We will be able to make better decisions so that citizens can navigate through the material more easily. This information will help us strengthen our marketing plan and tactics so we can reach more Calgarians in the Fall of 2012, we can improve our search engine optimization so that people can more easily reach the site and we can better understand what information citizens were interested in so that we can add to and enhance the content as we move into further phases.

Visitor Summary	
Visitors	2663
Visitors Who Visited Once	2558
Visitors Who Visited More Than Once	105
Average Visits per Visitor	1.06

Visit Summary	
Visits	2824
Average per Day	97
Average Visit Duration	00:03:37
Median Visit Duration	00:00:56
International Visits	10.73%
Visits of Unknown Origin	0.00%
Visits from Your Country: Canada (CA)	89.27%

Geography Summary

Countries	Visits
1. Canada (CA)	2521
2. United States (US)	179
3. ** 72	72
4. Libya (LY)	15
5. Philippines (PH)	3
6. Greece (GR)	2
7. Turkey (TR)	2
8. Brazil (BR)	2
9. India (IN)	2
10. Hong Kong (HK)	2
11. United Kingdom (UK)	2
12. New Zealand (NZ)	2
13. Australia (AU)	2
14. Portugal (PT)	1
15. Eritrea (ER)	1
16. China (CN)	1
17. Croatia (Hrvatska) (HR)	1
18. Bosnia and Herzegovina (BA)	1
19. United Arab Emirates (AE)	1
20. Romania (RO)	1

Cities	Visits
1. Calgary, Canada	1931
2. Chantilly, Virginia, United States	115
3. Montreal, Canada	87
4. Edmonton, Canada	74
5. Reserved, **	72
6. Toronto, Canada	63
7. Brampton, Canada	39
8. Vancouver, Canada	23
9. Mountain View, California, United States	22
10. Waterloo, Canada	21
11. Burlington, Canada	16
12. Tripoli, Libya	15
13. Etobicoke, Canada	15
14. New Minas, Canada	14
15. Lethbridge, Canada	14
16. Burnaby, Canada	12
17. Medicine Hat, Canada	9
18. Mississauga, Canada	12
19. Medicine Hat, Canada	9
20. Mississauga, Canada	9

Page Pathways Visitors Took Most Often

(Specified start page with the various paths visitors took from it.)

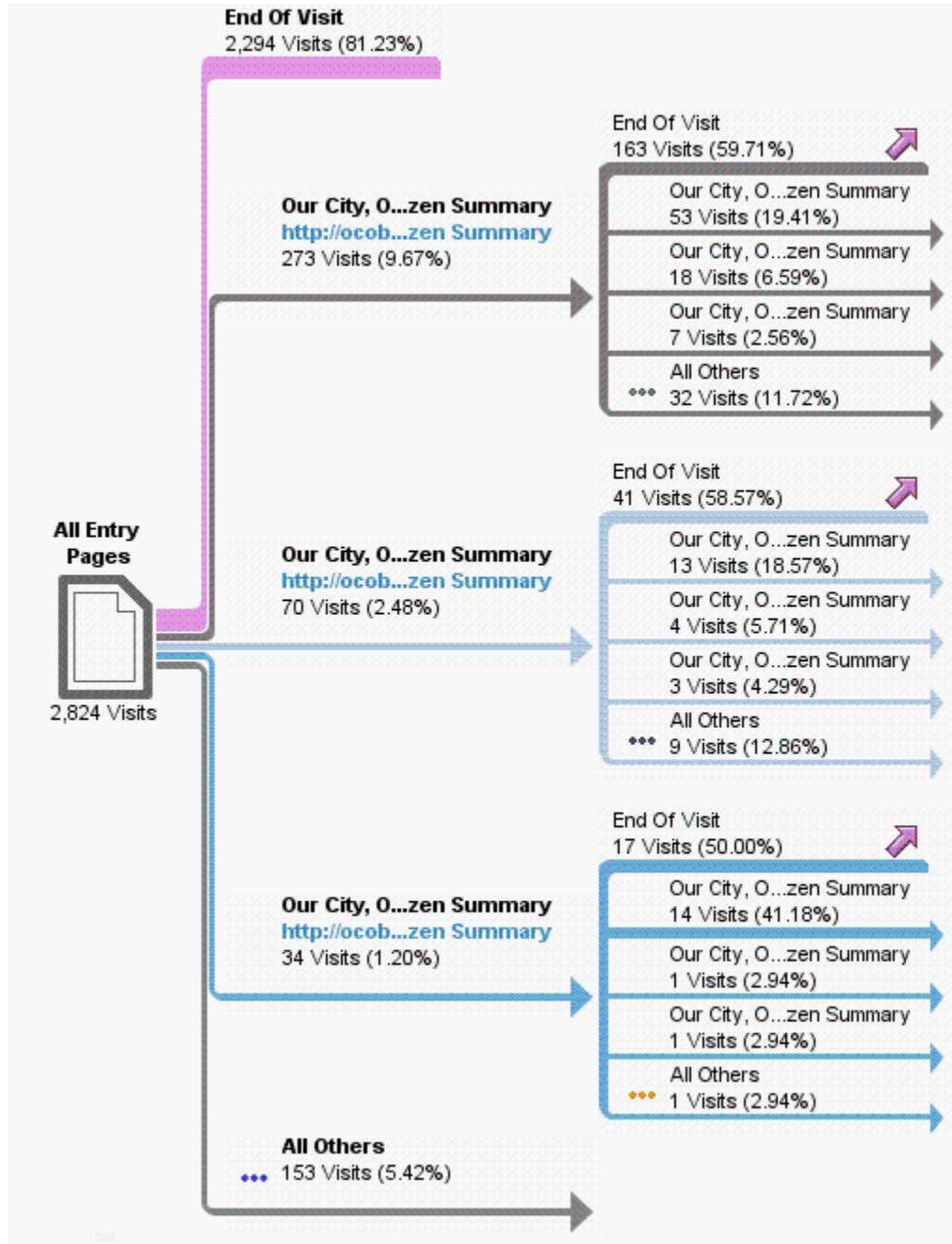

Pathway

1. 2824 Visits **started** at homepage and 2294 (or 81%) ended on homepage.
<http://ocobof.blogspot.ca/>
2. 273 Visits **started** at homepage, **clicked through** to Adjustments page, and 163 visits(or 60%) ended visit on homepage.

<http://ocobof.blogspot.ca/2012/05/adjustments-2013-2014.html?WT.ti=Our+City,+Our+Budget,+Our+Future:+Citizen+Summary>

3. 70 Visits **started** at homepage **clicked through** to Let's Talk page, and 41 visits (or 59%) ended on homepage.
<http://ocobof.blogspot.ca/2012/05/lets-talk.html?WT.ti=Our+City,+Our+Budget,+Our+Future:+Citizen+Summary>
4. 34 Visits **started** at homepage, **clicked through** to Welcome page, and 17 (or 50%) ended on homepage.

<http://ocobof.blogspot.ca/2012/06/welcome.html?WT.ti=Our+City,+Our+Budget,+Our+Future:+Citizen+Summary>

5. 153 Visits **started** at homepage, visited Other,

Referring Site	This report identifies web sites that refer visitors to your site. The top referrers are your site's primary acquisition channels, and may include a partner sites, search engines, portals or marketing programs.
Site	Visits
1. Direct Traffic	989
2. http://www.facebook.com/	416
3. http://www.calgary.ca/	318
4. http://ocobof.blogspot.ca/	277
5. http://mycity/	253
6. http://calgary.kijiji.ca/	79
7. http://t.co/ (twitter)	64
8. http://www.google.com/	50
9. http://www.ask.com/	46
10. http://www.calgarycitynews.com/	35
11. http://blog.calgarymayor.ca/	23

Search Phrases	
1. budget adjustments	
2. planning	
3. police	
4. our city our budget our future	
5. planning and building department	
6. policing strategies	
7. budget adjustments 2013	
8. budget adjustment	
9. our city our budget our future engagement	
10. basement suites for rent in calgary in airdrie alberta	
Mobile Devices	
Device	Visits
1. Apple iPad	268
2. Apple iPhone	146
3. Android Device	29
4. BlackBerry	13
5. BlackBerry 9700	7
6. Samsung Galaxy Tab	6
7. HTC	5
8. Samsung	4
9. BlackBerry 9780	4
10. Motorola MB860	3
11. Apple iPod Touch	3