

# PLAYSAFE: Don't Let It Happen to You

## Discussion Questions

Choose from the full-length video or any of the segments to show your group. Once you have made your selection, you can refer to the following questions to help you get started and generate a discussion.

### Before the Screening

For younger audiences (under 12):

- Ask the group to look for any dangers they recognize from their own homes and/or neighbourhoods and to take note of the activities they see the children participating in with their artificial limbs.

For older audiences (12+):

- Ask the group to pay attention to what the children say about their artificial limbs and to listen for tips on how to PLAYSAFE.

### After the Screening

For younger audiences (under 12):

- What are some examples of “mean machines?” In what kinds of places can you find “mean machines?” (i.e., in the country, in the city, by the water, on the road, etc.)
- What are some actions you can take to make sure that you PLAYSAFE? What does it mean to spot the danger before you play?
- What were the children doing when their accidents happened?
- Did you see any of the children participating in activities that you enjoy? (This will help to emphasize that while amputees may do things differently, they are no different than other children.)

For older audiences (12+):

- Was there anything in the video that surprised you? What was it and why? What did you learn from it?
- What are some actions you can take to make sure that you PLAYSAFE? How can you spot the danger before you play?
- What were the children doing when their accidents happened?
- Did you see any of the children participating in activities that you enjoy? (This will help to emphasize that while amputees may do things differently, they are no different than other children.)

### SAFETY WALK™

To close the presentation, you can hand out the SAFETY WALK resources (available on our website) to your group. With the guidance of an adult, a SAFETY WALK can be a fun activity to help children identify dangers in their own neighbourhoods and prevent accidents from happening.



Let us know  
how it went!  
Contact us with  
your feedback.

For additional  
information and  
handout materials,  
please contact  
PLAYSAFE.

# SAFETY WALK

## Family Worksheet

After your SAFETY WALK, fill in this worksheet to take note of what you saw.

In and around our home, we saw:

---

---

---

In our neighbourhood, we saw:

---

---

---

On the way to school/at the park/on the farm, we saw:

---

---

---

Other dangers we saw were:

---

---

---

### Discussion Questions

- What can we do to remove or avoid the dangers we saw?
- What can we do to make our family and friends aware of the dangers?
- Did we learn about any new hazards we didn't know about before? What were they?



# Outdoor Safety Word Search

Before you head outside to play, you should always look out for potential dangers, such as cars or trains. Can you spot the other dangers hidden in this word search? (Hint: Words can be hidden backwards, forwards or diagonally.)

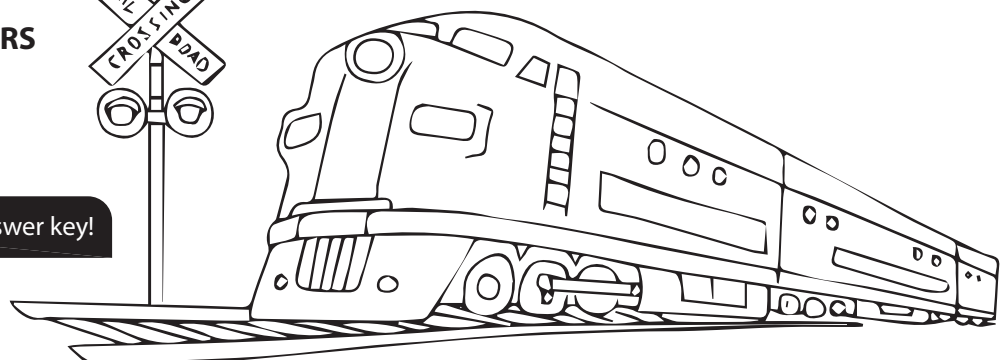
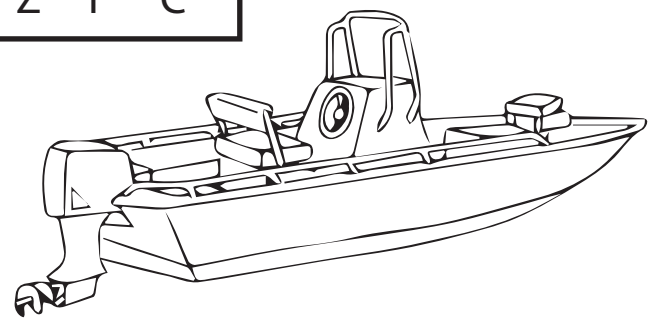
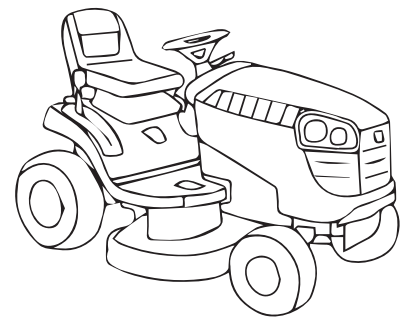
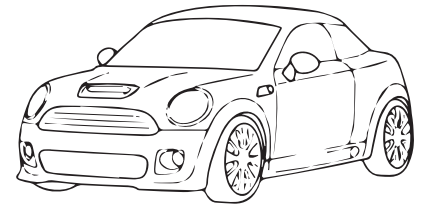

- |                    |                 |
|--------------------|-----------------|
| 1. BOAT            | 10. POOLS       |
| 2. BUS             | 11. POWER LINES |
| 3. CARS            | 12. RIVERS      |
| 4. COMBINE         | 13. ROADS       |
| 5. CONSTRUCTION    | 14. SEWERS      |
| 6. ELECTRIC FENCES | 15. SNOW PLOW   |
| 7. GRAIN AUGER     | 16. TOOLS       |
| 8. ICE             | 17. TRACTORS    |
| 9. LAWN MOWER      | 18. TRAIN       |

Find the answers to the word search on the answer key!

# Bike Safety Crossword Puzzle

Can you complete the crossword using your knowledge of safe cycling?

Use the hints below to fill in the mystery words.

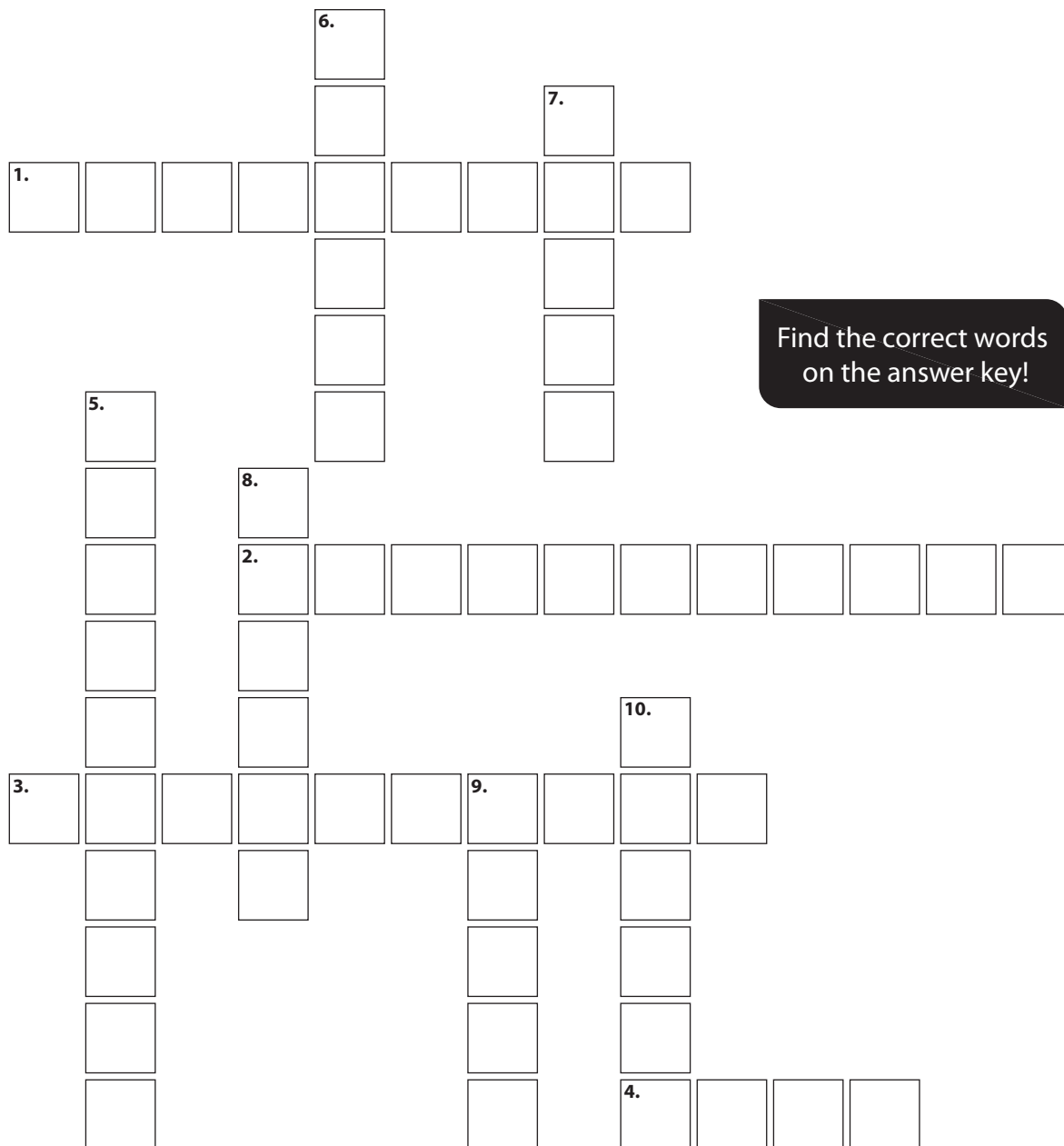

Find the correct words on the answer key!

## Across

1. You wear this on your helmet to see at night.
2. These gestures tell others where you are going.
3. You put these on your wheels, seat, helmet and clothing to be seen at night.
4. You sit on this while riding your bike.

## Down

5. You hold onto these to steer.
6. You wear this on your head to protect it.
7. You make sure this is well-oiled.
8. These are round and rotate to move you forward.
9. These are rubber tubes that go on your wheels.
10. You use these to stop your bike.

# Answer Key

## Outdoor Safety Word Search

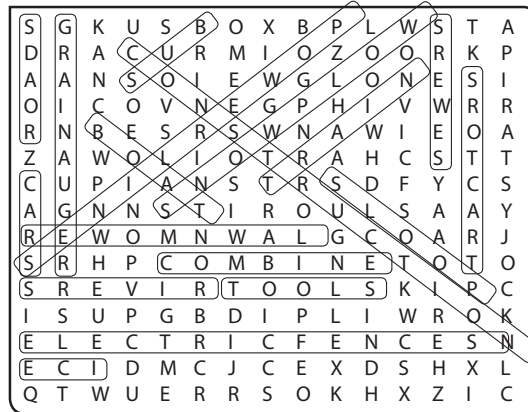

## Bike Safety Crossword Puzzle

### Across

1. headlight, 2. handsignals, 3. reflectors, 4. seat

### Down

5. handlebars, 6. helmet, 7. chain, 8. wheels, 9. tires, 10. brakes