

Calgary



A Guide to Skateboard and Sports Ramps

November 2016



Overview



Things to consider

This guide will help you understand:

- The rules for skateboard and sports ramps; and
- How to maintain relationships with your neighbours.

This guide contains links:

- To the Land Use Bylaw 1P2007 for rules; and
- To the Community Standards Bylaw for noise standards and tips for reducing noise.



Questions?

- Call (403) 268-5311; we are here to help.

What are sports ramps?

Skateboard and sports ramps:

- Are structures or combinations of structures that are used to provide a surface upon which an individual may use or operate a skateboard, bicycle, scooter, roller skates or other similar devices.
- Can come in many different sizes, shapes and materials.
- Can be non-fixed and movable.
- May include re-purposed furniture, or other structures that have useable, skateable or bikeable surfaces.



In the case of any discrepancy between anything in this guide and Land Use Bylaw 1P2007, the provisions of Land Use Bylaw 1P2007 prevails. This guide may not accurately reflect all amendments to Bylaw 1P2007. Nothing herein relieves any person from complying with any federal or provincial law or regulation, bylaws, or any requirements of any lawful permit, order or licence. The examples shown in this guide are illustrative only. The guide does not, and is not intended to replace Bylaw 1P2007. The wording of Bylaw 1P2007 will form the basis of review for all development permit applications. This guide does not bind council, the development authority, subdivision authority or the subdivision and development appeal board. Updates and changes to this guide may occur at the sole discretion of The City of Calgary, Planning and Development. It is the sole responsibility of the user of this guide to ensure that they have the most current version of the guide, which is available online at calgary.ca

Where can you build?



What land use district are you in?

- To find out what Land Use District you live in visit: <https://maps.calgary.ca/MyProperty/>. If your land use district starts with an “R” or an “M”, backyard skateboard and sports ramps are allowed. You must live in a Low Density Residential or Multi-Residential District.
- Higher density areas of the Centre City like the downtown do not have access to back yard ramps.

Is a permit required?

- Skateboard and sports ramps built in low-density residential or multi-residential districts **do not require** a development permit **if** the structures meet the rules of the Land Use Bylaw.

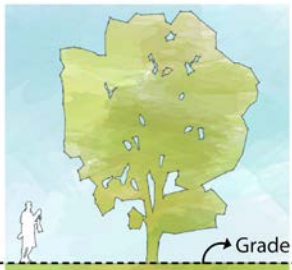

- Above grade structures must be located:
 - In residential backyards (between the rear facade of the main residential building and the rear property line);
 - Further than 1.2 metres from the side and rear property lines; and
 - Away from any fence, deck, and accessory residential building like a shed or garage.
- Ramps cannot be attached to a deck, other structure, building or fence.
- Some parcels will not be large enough to build up to the maximum allowable envelope size (see page 4).
- If you want to build a structure that is larger than the maximum allowable envelope size (see page 4), you will need a **development permit**.

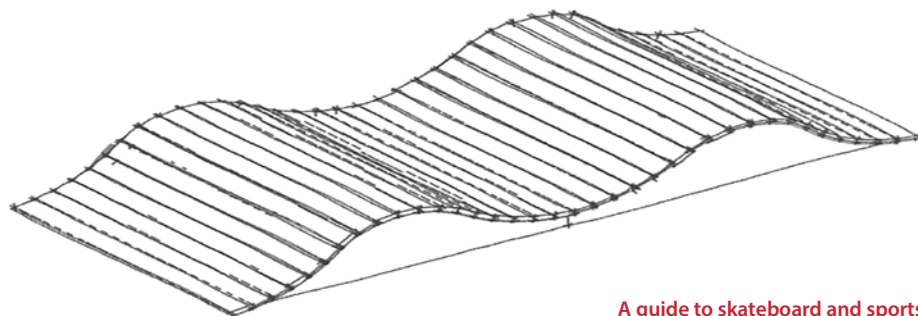

What is maximum Size?



Does it fit within the maximum allowable envelope size?

- The envelope is an invisible box with a specific height, width and length into which all the skateboard and sports ramp structures must be contained. The maximum allowable envelope size dimensions are:
- **1.5 metres high (height is measured from grade);**
- **5 metres wide; and**
- **6 metres long.**

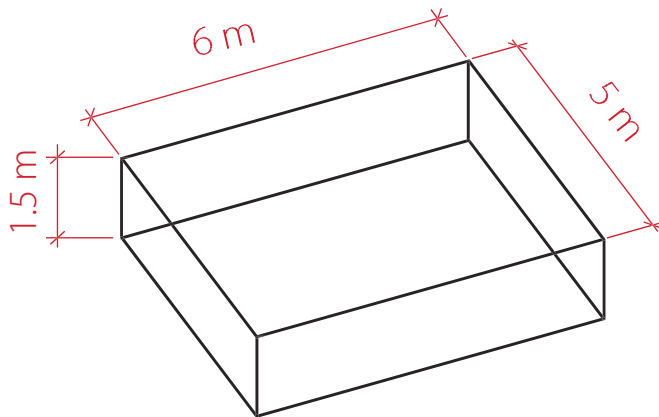

These are examples of fun structures

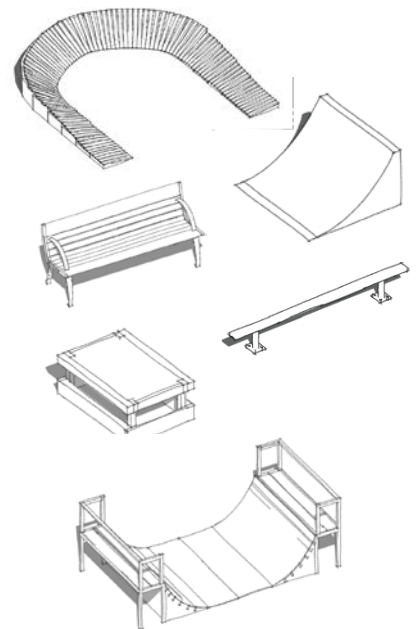

What can you build?

- Any fun structures that fit in the envelope!
- One envelope is allowed per parcel.
- You might build something smaller than the maximum allowable envelope size.

Safety railings:

- Safety railings can be located outside the maximum allowable envelope size, but must not be skateable or bikeable.

Skateboard and Sports Ramp Examples

Bird's eye view of house and dirt BMX track ramps

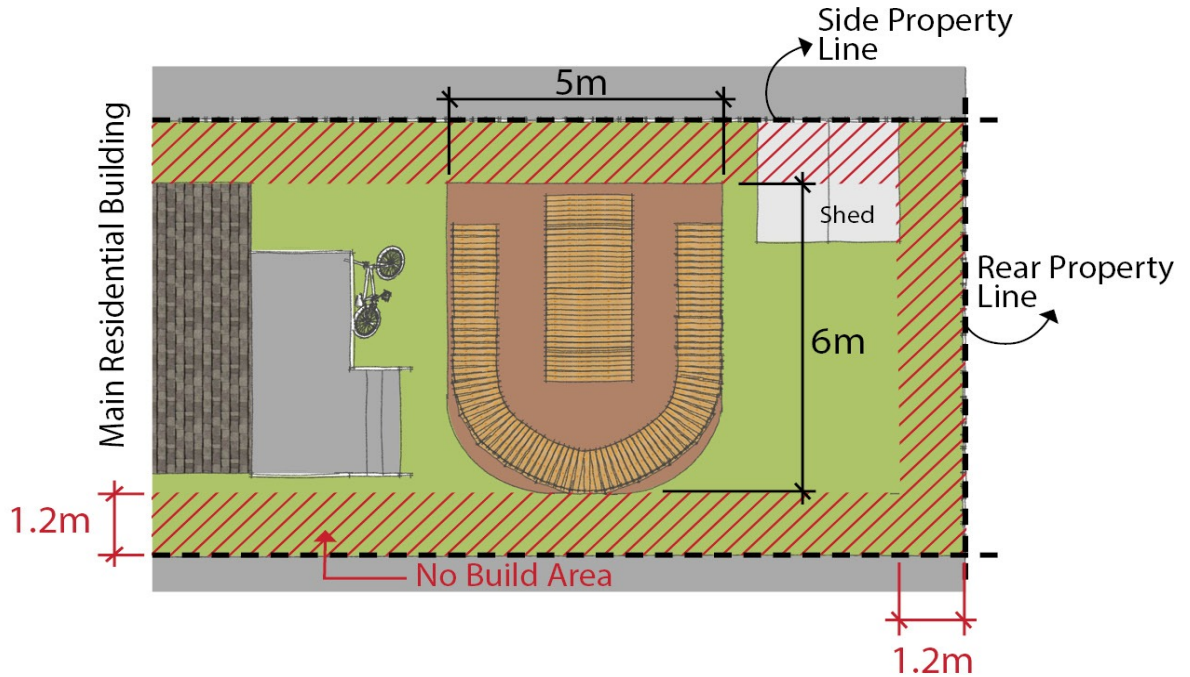

Skateboard and Sports Ramp Examples

Bird's eye view of townhouse dwelling

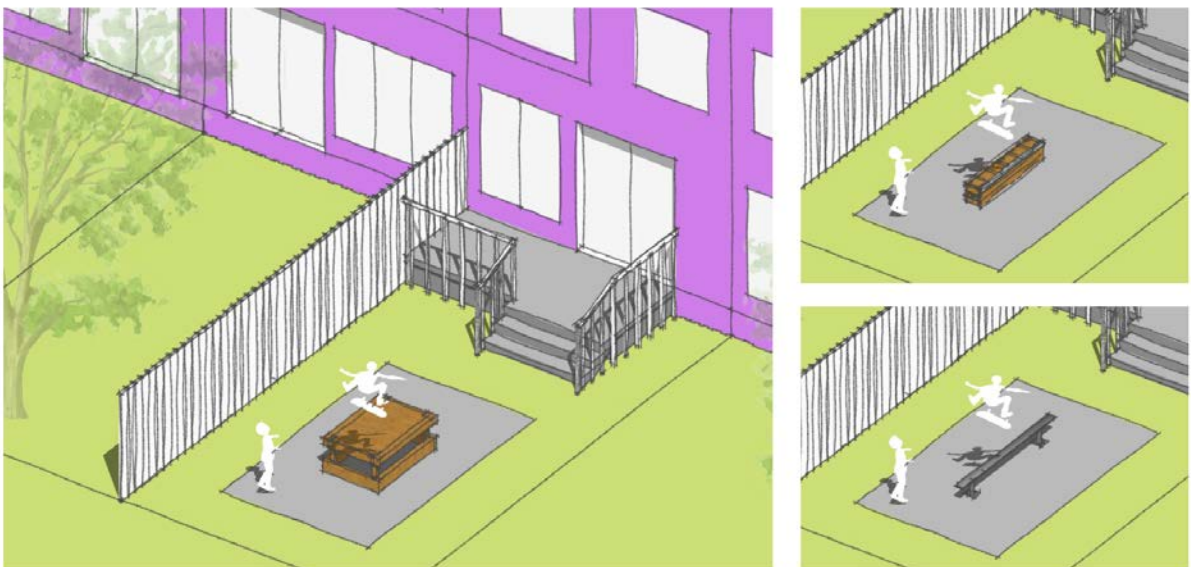
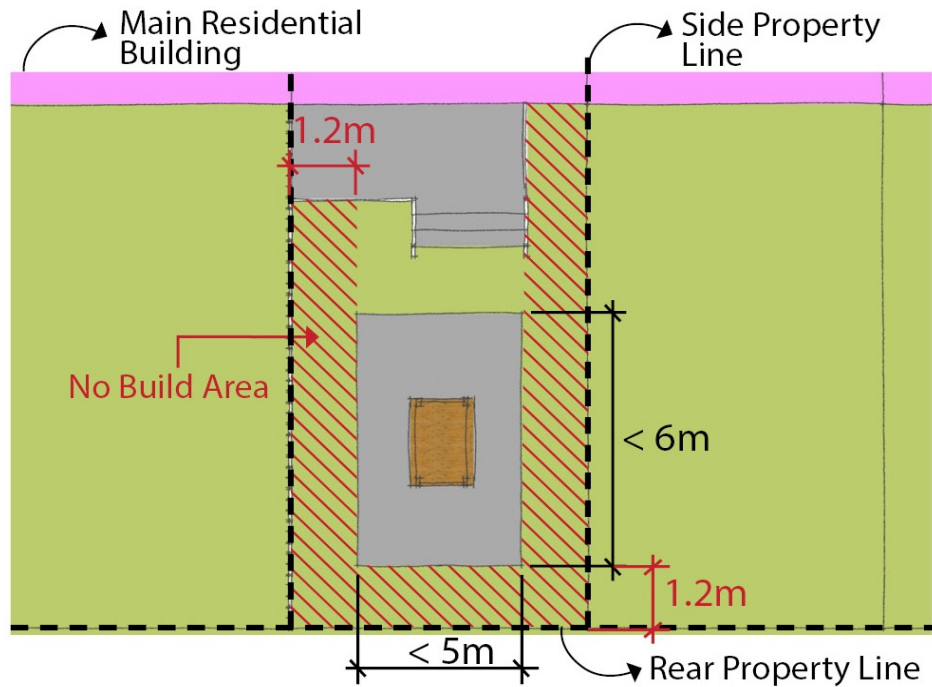

Skateboard and Sports Ramp Examples

Bird's eye view of multi-residential apartment

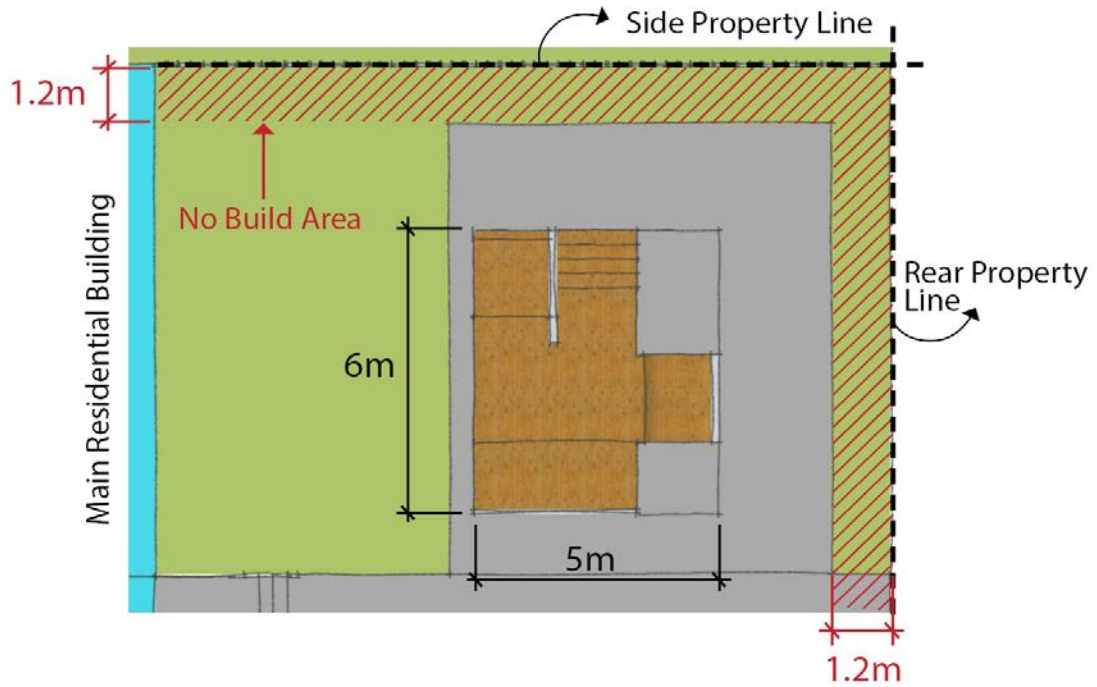

Tips



Being a good neighbour

What you can do to be a good neighbour?

- Talk to your neighbours.
- If you are a tenant or building owner on a multi-residential parcel, you will likely require permission from the landlord, property manager or a condominium board, before you start to build.
- Follow these [noise-reducing tips](#) when building or retro-fitting your ramp.
- Follow the [rules in the Community Standards Bylaw](#), which set sound limits for day-time and night-time, and prohibit certain activities after 10 p.m. including the use of sports ramps.
- The Calgary Association of Skateboarding Enthusiasts says “To ensure a smooth ride and to mitigate noise”:
 - ✓ Use high quality sanded plywood, Skatelite, or a similar material for the ramp surface;
 - ✓ The seams on the surface should be as tight as possible. Have precise connections and use shims to ensure the seams meet with little or no cracks; and
 - ✓ Place long flathead wood screws every foot or less on the surface to secure the surface to the base.
- Respect the size and setback rules by always referring to the [Land Use Bylaw](#). See Sections 13(130), 25(1)(e.1), 60(2)(b), 61(2)(b), 342.2, and 571.2 specifically.
- Always prioritize safety for yourself and others.

