

**BULLETIN RB06-043**

(Updated 2015 Dec 18)

**HORIZONTAL FIRE DAMPERS IN COMBUSTIBLE FLOOR ASSEMBLIES**

Reference: Article 3.1.8.9.

Article 3.1.8.9. "Installation of Fire Dampers"

**Question:**

The following detail has been accepted by the Building Regulations Division for the past several years.

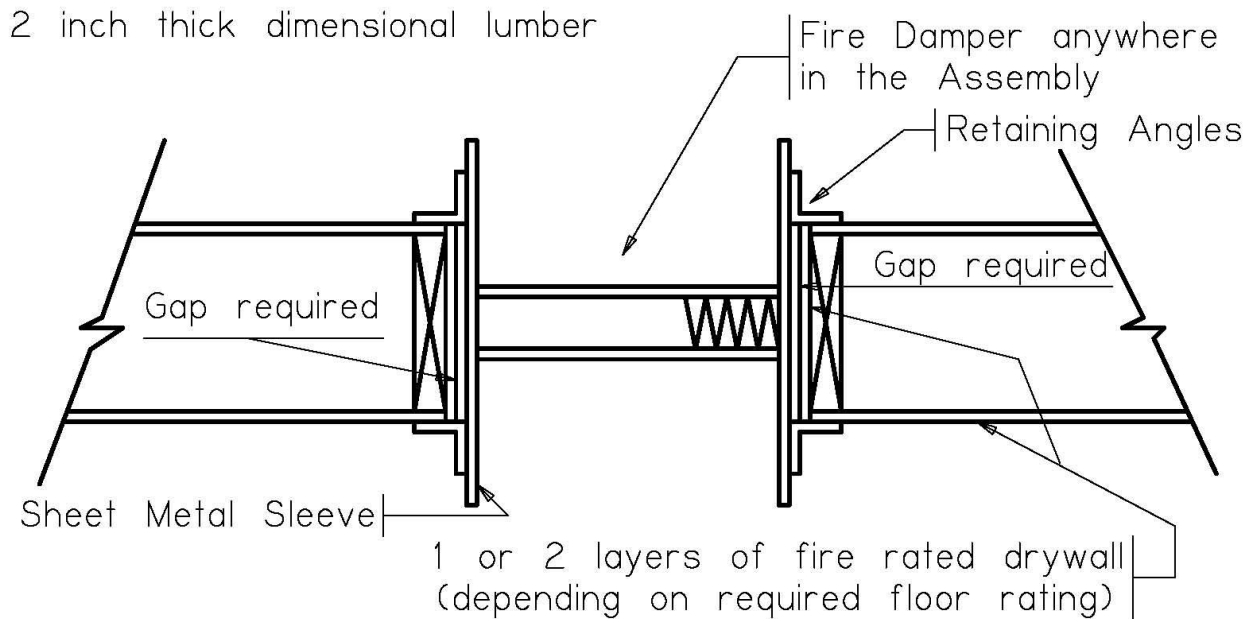

It has been queried whether the detail below is also acceptable, since doubts were expressed about the ability of I-joists to support the drywall and the damper in a fire situation as well as sawn lumber. (The only difference is that the sawn lumber sections have been replaced by engineered joists)

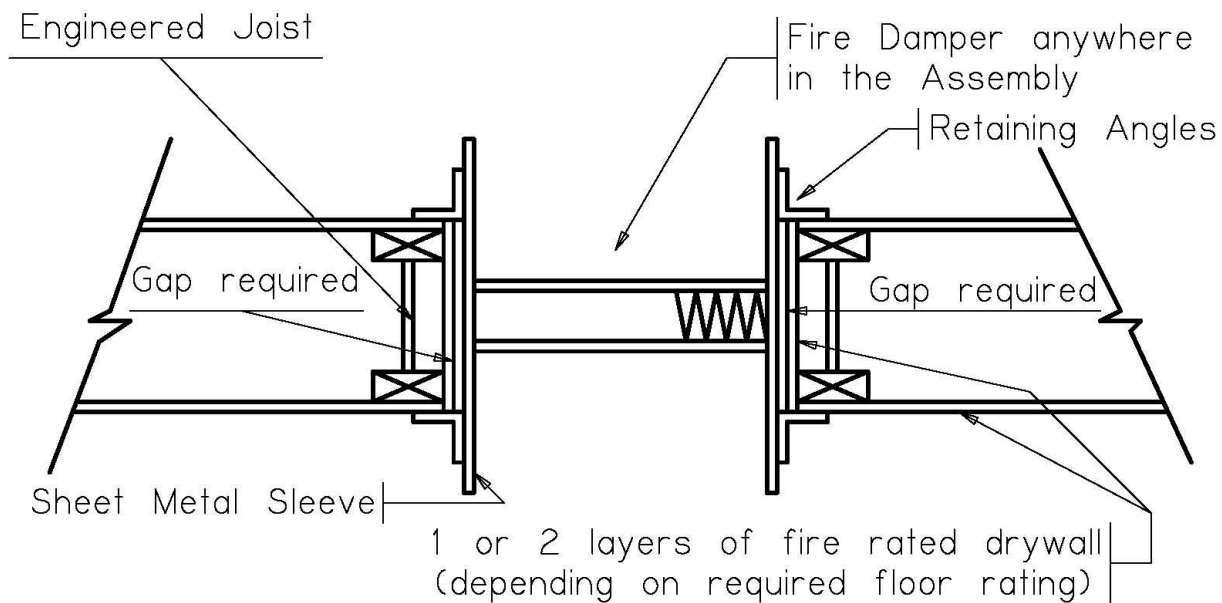

**Commentary / Relevant Facts / Conclusion:**

Drywall provides an equal degree of fire protection in both assemblies. Also, the fire damper construction and installation are the same. Therefore, the overall performance of both assemblies is judged to be equal.

**Notes:**

- a) Fire damper installation and sleeve breakaway joints and retaining angles to follow manufacturer's instructions.
- b) Fire dampers are not to be sealed with caulking or fire stopping unless required by manufacturer.
- c) Gap required between sheet metal and opening to be as recommended by manufacturer.

Chief Building Inspector

**This bulletin is issued by The City of Calgary Inspections & Permit Services.**

Unless stated otherwise, the Code references in this bulletin are to Division B of the Alberta Building Code 2014 (ABC 2014). Bulletins do not overrule the ABC 2014 nor constitute a relaxation of the Code. They serve to clarify the Code in areas where the latter is ambiguous or does not cover a specific topic. Bulletins are City of Calgary clarifications for staff use to enable consistency in the application of the Code. These bulletins should always be read in the context of the appropriate requirements of the Code.